

CE

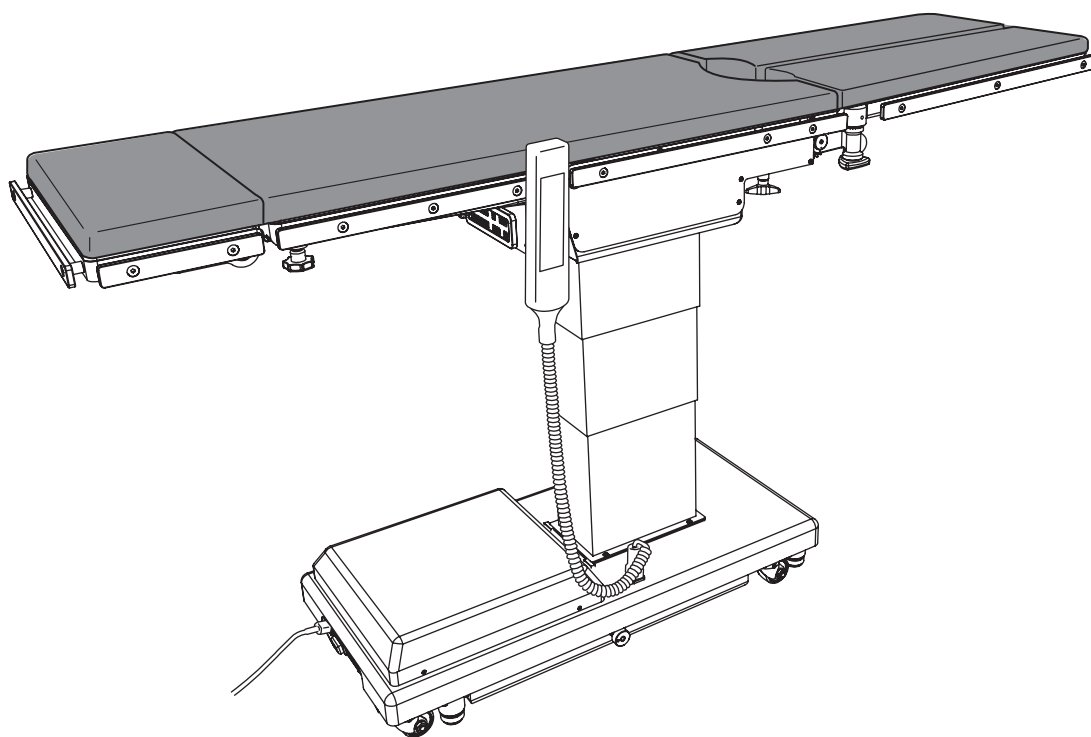

Operating Table MOT-VE100 Operator's Manual



This operating table is designed for medical operations. Using this operating table for any other purpose other than this intended use may cause serious injury.

The operator and the person in charge of the maintenance of this operating table must read this operator's manual thoroughly and understand the contents before operating, inspecting, adjusting and maintaining it.

Keep this manual for reference in a place where is readily accessible.

Table of contents

1.	Introduction	1
1.1	This manual	1
1.2	Intended use and this product	1
1.3	Accessories	2
2.	Safety precaution	4
2.1	Read thoroughly before using	4
2.2	Labeling	9
3.	Section Introduction	13
3.1	Main unit	13
3.2	Hand controller	14
4.	Operation	15
4.1	Installation and battery charging	15
4.2	Turning on/off the power	20
4.3	Operating the emergency stop switch	23
4.4	Fixing and unfixing the operating table	24
4.5	Tilting the tabletop laterally	25
4.6	Trendelenburg	26
4.7	Back section up/down	28
4.8	Changing the tabletop height	29
4.9	Flexing or reflexing the tabletop	30
4.10	Return to level	32
4.11	Adjusting the head section	33
4.12	Adjusting the leg section	35
5.	Maintenance and inspection	38
5.1	Inspection before and after use	38
5.2	Cleaning and disinfection	40
5.3	Maintenance by providers	40
5.4	Periodic replacement parts	41
5.5	Version information of the software	41
6.	Specification	42
6.1	Specification table	42
6.2	External view	44

7.	Troubleshooting	45
7.1	When the hand controller cannot be used.....	45
7.2	When the brake cannot be released.....	46
8.	Before contacting for repairs	47
App.-1	Electromagnetic Compatibility	49
App.-2	Glossary.....	52

1. Introduction

1.1 This manual

This manual contains information for safely and effectively using this product.

Before operating this product, read this manual thoroughly to understand how to operate and inspect the product.

Failure to follow these instructions could lead to serious injury.

The safety information is categorized as per the following so that the contents of warnings and cautions, and the details of warnings and cautions which are labeled on the product may be comprehended.



If this indication is ignored and the product is incorrectly used, serious injury or death may result.



If this indication is ignored and the product is incorrectly used, injury and/or damage to property may result.

NOTE

This notice notes additional information on the product's functions.

The warning and caution notices on this manual relating to operating and inspecting, apply to the intended use (surgical operations) of this product.

If the product is used for purposes other than surgery, the user is responsible in regard to safety for performing operations and inspections which are not contained in this manual.

1.2 Intended use and this product

This product is the operating table on which a patient is placed for surgical operations.

The product is intended to support a patient during surgical operations.

In conforming with the objectives of surgery, the product is equipped with features for adjusting its height, and for freely changing and setting the patient's body position.

The product uses both medical grade outlets and batteries as power sources.

This product is to be used by health care professionals, including but not limited to surgeons, nurses and biomedical technicians.

1.3 Accessories

■ Standard components and accessories

Flame-Retardant and Waterproof Pads (SUSANO Pad)
(for Head Section Type A, Back and Seat Section Type A,
Double Leg Section Type B)

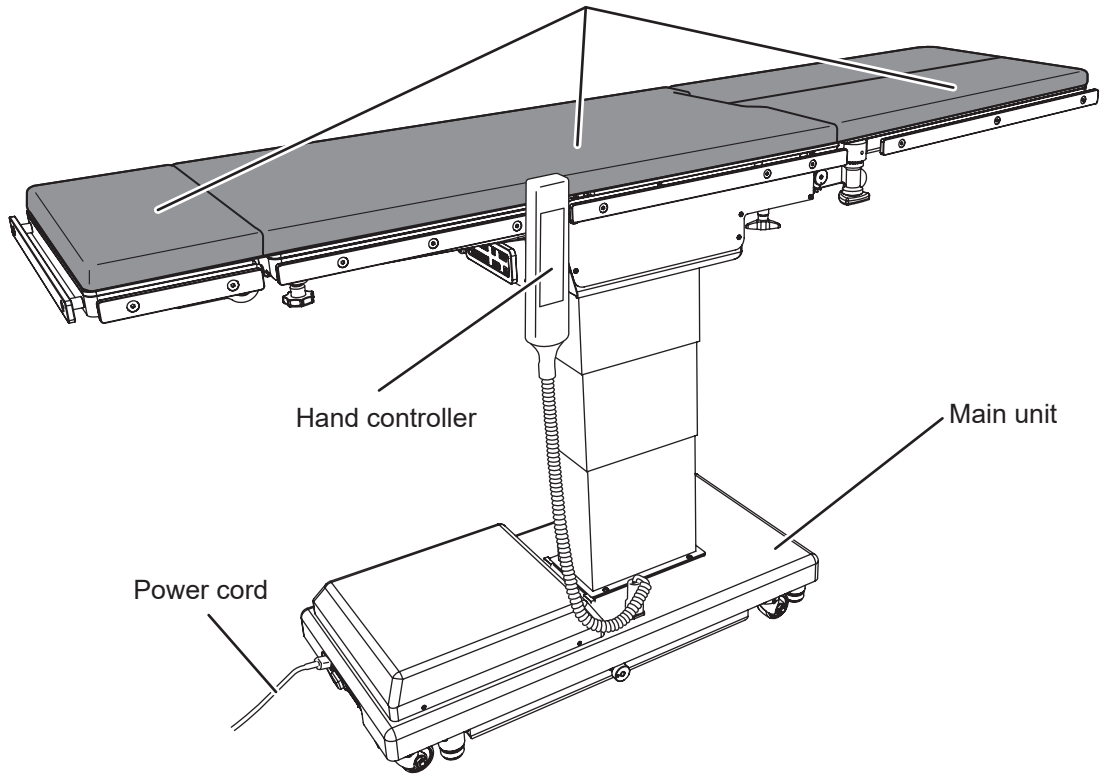

Operator's manual

■ Optional parts

● Flame-Retardant and Waterproof Pads (SUSANO Pad)

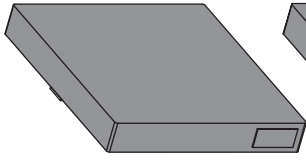

for Back Section
Type A

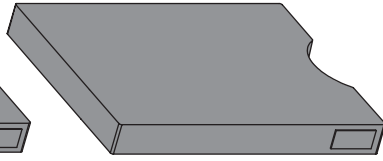

for Seat Section
Type A

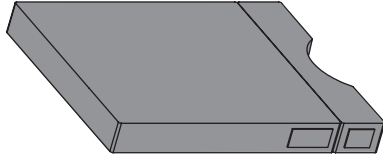

for Seat Section
Type B

2. Safety precaution

2.1 Read thoroughly before using

In using this product, carefully read the following warnings and cautions, and make sure to observe them. Any serious incident that has occurred in relation to the device should be reported to the manufacturer and the competent authority in which the user and/or patient is established.

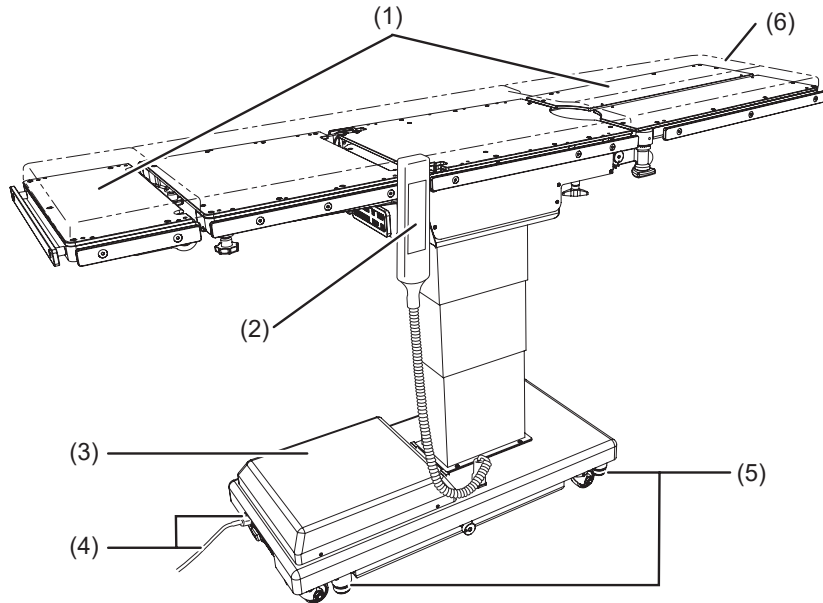

(1) Head section and leg section



Do not step or sit on the head section or the leg section(s).
The operating table may tip over resulting in injury.

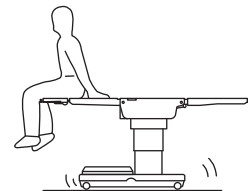

Before lowering the table or placing it in a reverse Trendelenburg position, check if there are any devices under the leg section.
If the leg section comes in contact with devices and it is subjected to excessive force, the operating table may be damaged.

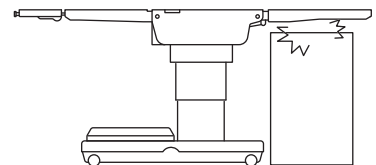

When transferring a patient from the operating table (Fig. a) or changing a patient's body position (Fig. b), do not apply excessive force on the head section or leg section.
The operating table may get deformed or damaged.

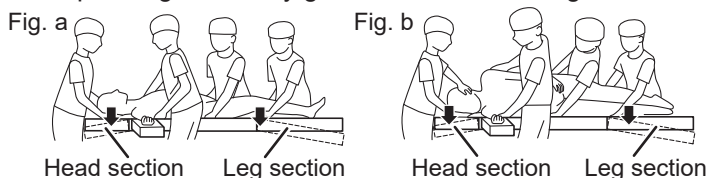

(2) Hand controller



CAUTION

- Do not forcibly pull the hand controller cord.
- Do not subject the hand controller to strong shocks. The hand controller may get damaged.

(3) Base



CAUTION

Do not place any objects on the base. An object may get caught and the operating table may get damaged.

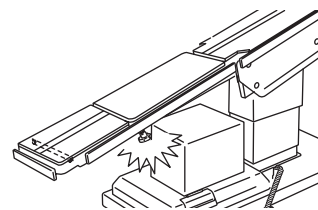

(4) Power cord and power connector



WARNING

- Do not place any heavy objects on the power cord.
- Do not roll over the power cord with a casted device.
- Do not forcibly pull the power cord.
- Do not place any objects in the place where the power cord is to be unplugged from the medical grade outlet, which would obstruct it from being unplugged.
- Take waterproofing measures such as covering the power connector with a plastic sheet, etc. so that liquids do not infiltrate inside of the power connector. If liquids infiltrate inside of the power connector, it may cause fire or damage.

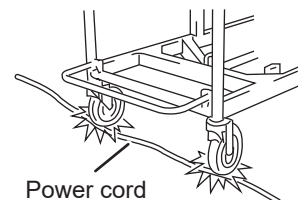

(5) Installation of the operating table



WARNING

- Do not install the operating table on an uneven floor.
- Do not place a pad under the base for raising the operating table. The operating table may tip over resulting in injury.

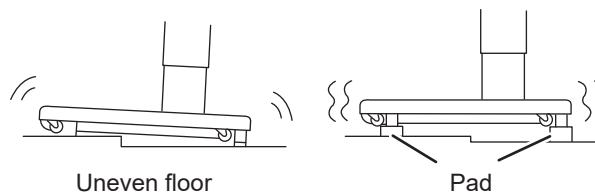

(6) Table pad



WARNING

Make sure to securely attach the table pads to the operating table so that they do not come off. The table pads may come off, and the patient may get injured.



CAUTION

- Attach the table pads straight along the Velcro fastenings from the edges. Especially, attach long table pads while holding them with your hands so that the surfaces do not get wrinkled. If the table pads rise up or buckle, they may get deformed or damaged.
- Do not apply tape, etc. directly on the table pads. Otherwise, they may get damaged.
- Place and store the table pads in flat places. Leaning or bending may get deformed or damaged.
- Do not store operating table accessories or other medical devices, etc. on the table pads. Otherwise, they may get deformed or damaged.
- The table pads maintain waterproofness when they are properly attached in their usage. If the table pads are attached other than the proper placement method in their usage, and liquids infiltrate inside, it may cause degradation.
- If liquids get on the table pads waterproof fastener, wipe them off quickly. If the waterproof fastener gets wet and the liquids infiltrate inside, it may cause degradation.
- Do not open the table pads waterproof fastener. If liquids infiltrate inside, it may cause degradation.

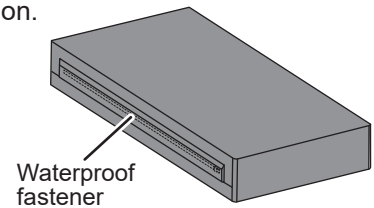

■ Patient's position during surgical operation



WARNING

Position the patient's body 10 mm (0.39 in) or more away from the metal side rail. The side rail may produce high temperatures due to the usage of electric scalpels, etc., which may result in a burn injury.

● Positioning the patient

Follow the steps below to position the patient.

- 1. Attach the accessory table pads onto the tabletop with their Velcro fastenings aligned with each other.**
- 2. Put the patient on the table pads.**
- 3. Position the patient according to the purpose of the surgical operation.**



CAUTION

Have the person who operates the operating table to operate it in a position where the emergency stop switch can be immediately pressed, and the patient's condition can constantly observed.

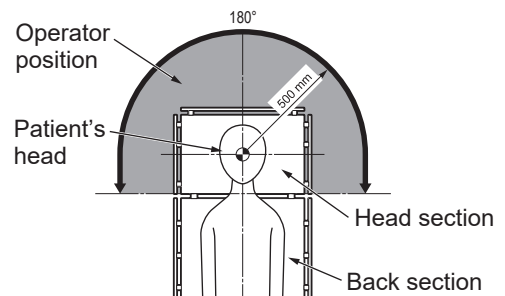

Other



- **Prohibited**

- Do not disassemble and/or modify the operating table. Otherwise, malfunction may occur.

- **Patient position**

- When using the tabletop or accessories to secure a patient's body position, always observe the patient's condition. Being in the same position for long periods of time causes neuroparalysis or bedsores.

- **Other medical electrical equipment to be used together with the operating table**

- When using a high-frequency surgical equipment and/or a cardiac defibrillator etc. with the operating table, refer to their operator's manual provided by the manufacturers and observe the precautions and usage. Improper precautions and usage may cause the operator or the patient to get burned and/or devices to malfunction.
- When using medical electrical equipment etc. with the operating table, check that the operating table does not malfunction before using it. Electromagnetic interference may result in malfunctioning of the operating table.

- **Weight capacity**

- Do not apply loads which exceed the weight capacity (total of the patient and accessories)*. The operating table may not function, which may result in failures.
* Elevation: 250 kg (555 lbs) / Operations other than elevation: 250 kg (555 lbs)

- **Preventive maintenance and inspections**

- Make sure to inspect and maintain the operating table before and after use. The operating table may require replacement of the parts due to significant wear, deterioration, and/or breakage depending on the usage period and frequency of use.
- For preventive maintenance and inspections, contact your distributor or Mizuho directly.

- **Antistatic measure**

- Do not use the operating table on floors and/or with accessories that do not possess static electricity countermeasures. This may impede surgical operations.
-



● **Devices and accessories used together with this product**

- Before using other devices or accessories, thoroughly read the instruction manual of the devices and make sure that the operating table is not affected adversely. Before fitting on accessories from third party companies, contact your distributor or Mizuho. Some accessories cannot be fitted on.
- While operating the operating table, check the position of other devices or the accessories used with them. They may come in contact with each other during the operation, the operating table, devices and/or accessories may get damaged.
- For hygiene, be sure to use sterilized drapes on the areas on this product where the patient comes into contact with it.

● **Moving and transporting**

- Do not move the operating table with a patient on it.
- Follow the procedures below to move the operating table.
 - * Before moving the operating table, disinfect the entire operating table in order to prevent infection.
 1. Turn off the power and disconnect the power cord from the medical grade outlet.
 2. Check if the handles and levers are in fixed positions, and each section is fixed firmly.
 3. Unlock the brakes, and move the operating table.
 - * Do not move the operating table by pulling on the head section or the leg section.
- The operating table should be transported with the following conditions met.
 1. Disinfect the entire operating table before transporting it.
 2. Take measures to prevent it from tipping over, such as lowering the tabletop to the bottom position.
 3. Actuate the brake.
 4. Suitably position cushioning on the product to prevent it from getting damaged during transport.
 5. Store the product in a container so that it does not get exposed to dust, and the weather.

● **Disposal**

- In accordance with the European Union Waste Electrical and Electronic Equipment (WEEE) Directive, all electrical components and batteries must be disposed of in accordance with local regulations. Please contact your local distributor for proper disposal.
 - Pay special attention to the following disposals:
 - a) Hydraulic Fluid
 - b) Lead Acid Batteries
-

2.2 Labeling

The operating table is labeled at the locations shown as below. Before use, make sure to understand the contents of the labels.

Warning and Caution labels

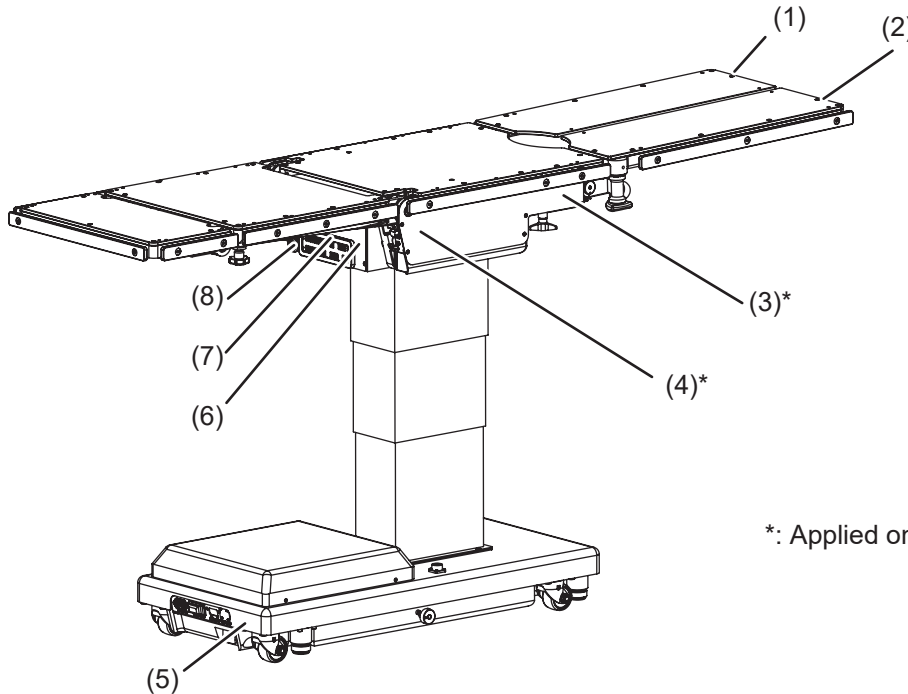

*: Applied on both sides.

(1) C655650□



(2) C655608□



(3) C653624□

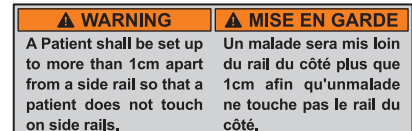

(4) C655732□

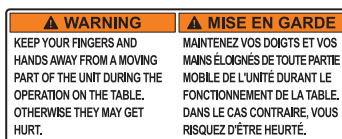

(5) C656740□

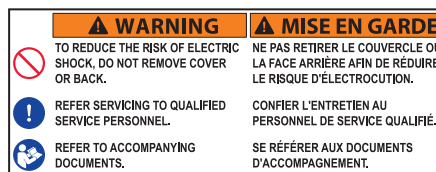

(6) C657333□

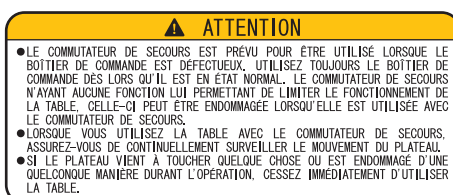

(7) C655803□

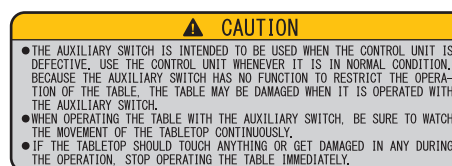

(8) C653614□



Other labels (1/2)

2

Safety precaution

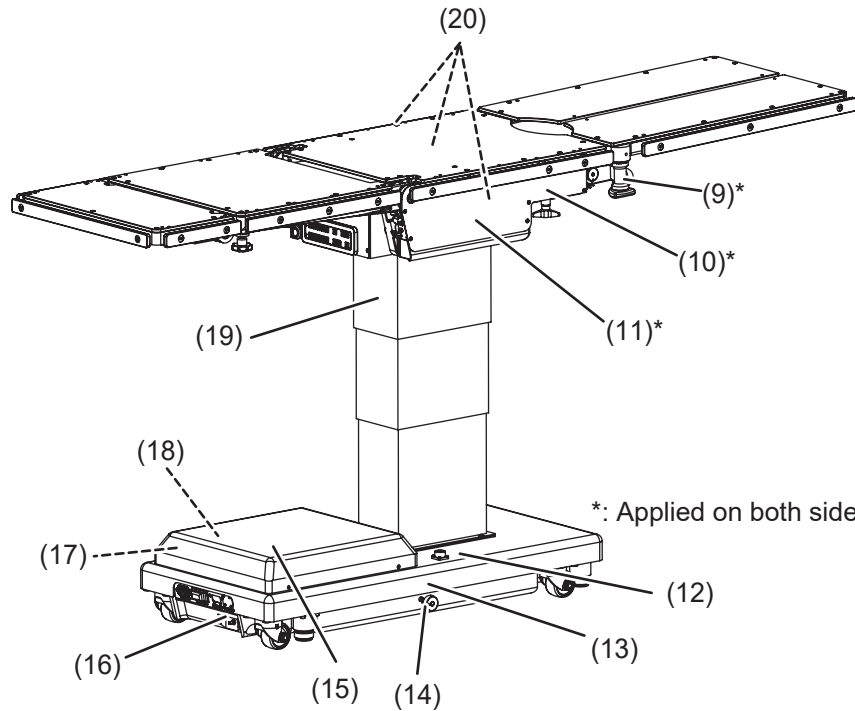

*: Applied on both sides.

(9) C600516□



(10) C655724□



(12) C655648□

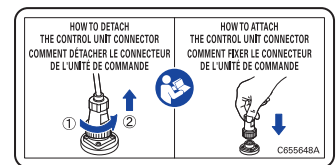

(11) C640032□



or C640033□



or C640034□



(13) C653515□



(14) C653516□

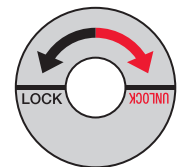

(15) C642002□



(16) C653513□



(17) C655002□



(18) C655684□



(19) C655683□

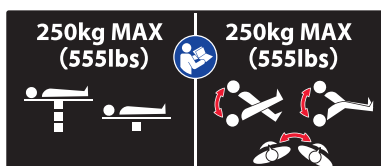

(20) C655001□



Other labels (2/2)

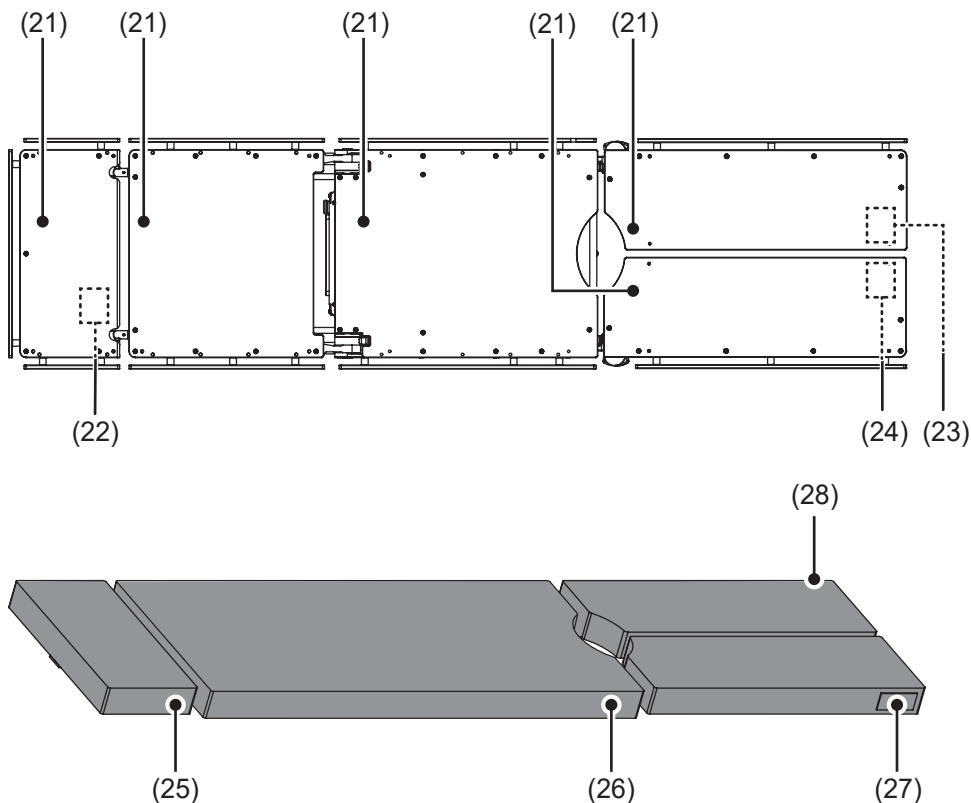

(21) C653620□



(22) C657305□



or C657348□



or C657344□



(23) C646104□



or C646105□



or C646106□



(24) C646101□



or C646102□



or C646103□



(ASIA)

(EU)

(US)

(25) PIN 558K5M1



(26) PIN 558K6M1





















(27) PIN 558K8M4



(28) PIN 558K8M3



■ Symbol mark for labeling

Symbol	Description	Label no.
	Indicates a possibility of injury or even death if operates the table without following the warning	(1) (2) (3) (4) (5) (6) (7)
	General prohibition sign	(1) (2) (5)
	No sitting	(1) (2)
	No stepping on surface	(1) (2)
	General mandatory action sign	(5)
	Emergency stop	(8)
	Refer to the operator's manual	(5) (8) (12) (15) (18) (19)
	Indicates AC power supply	(15)
IPX4	Enclosure Class (Splash-proof)	(15)
	Serial Number	(15)
	Catalogue Number	(15)
	Indicates waste disposal information	(15)
	European authorized representative	(15)
	Medical Device	(15)
	Equalization terminal	(16)
	Indicates protection against electric shock and defibrillator (Class B)	(21)
	Defibrillation - proof Type B applied part	(25) (26) (27) (28)
	Date of manufacture	(15)
	Manufacturer	(15) (25) (26) (27) (28)
	Conforms to BS 7177:2008 for medium hazard	(25) (26) (27) (28)

3. Section Introduction

3.1 Main unit

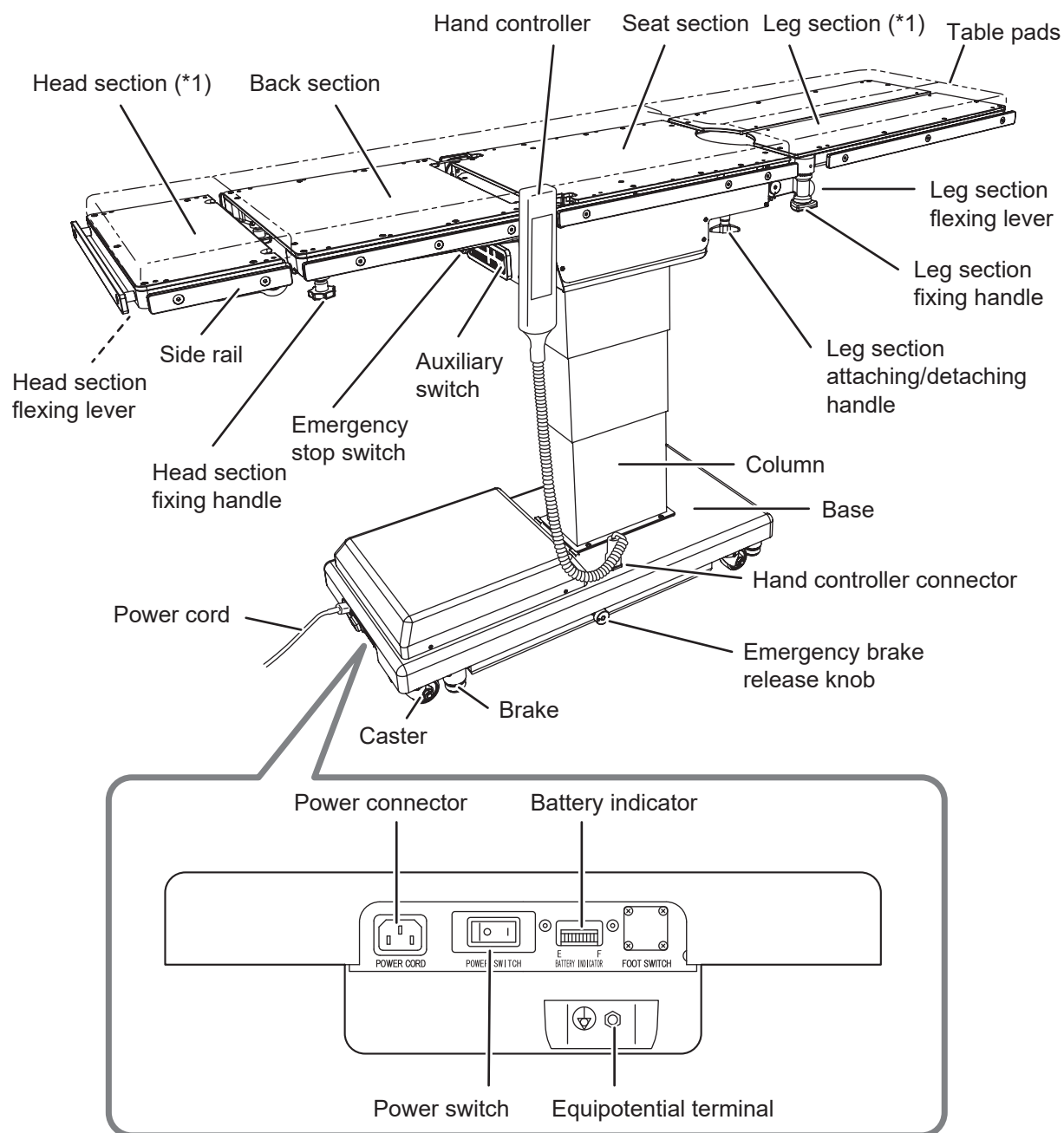

* 1: The head section and the leg section can be detached.

3.2 Hand controller

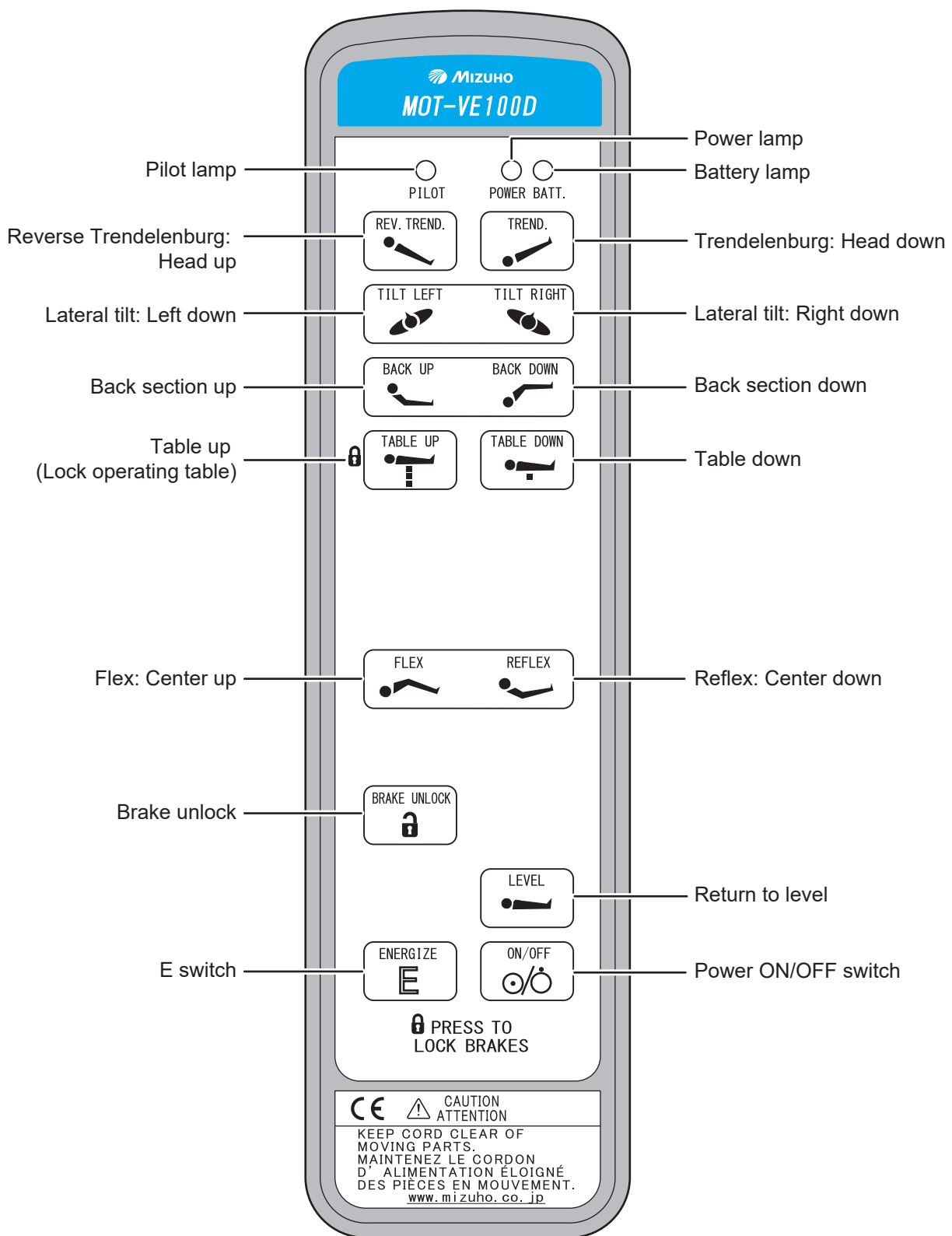

NOTE

- If  is pressed, the pilot lamp lights up. Pressing any function switch while the pilot lamp is lighting up, that function will operate while the switch is pressed.
- About 20 minutes of halting will be needed when operating the table continuously for about 3 minutes. If the motor gets overheated you will not be able to operate the table. When overheat occurs, about 90 minutes of rest will be needed to operate the table as usual.

4. Operation

4.1 Installation and battery charging



- Use the equipotential wire to ground the equipotential terminal to the medical grounding terminals. Prepare the equipotential wire yourself.
- When moving this product, carry it out with two or more persons.

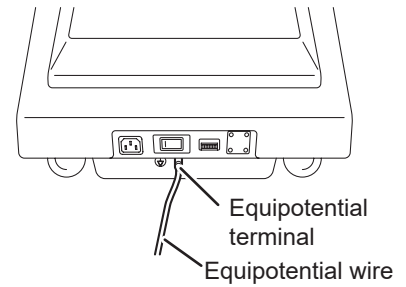

■ Installing the operating table

1. Move the operating table to a flat area.
2. Check the battery lamp.

If the battery lamp (orange) on the hand controller flashes, battery charging is required.

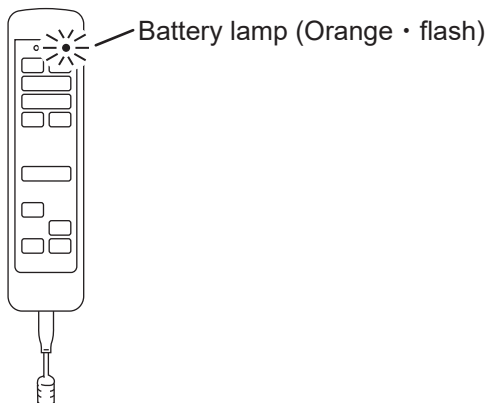

3. If the battery indicator shows empty (red), battery charging is required.

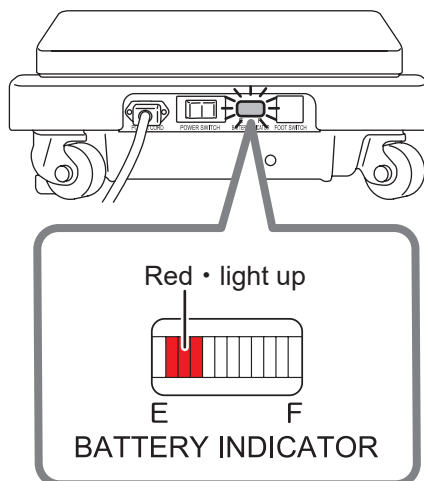

■ Installation space

This product requires the installation space shown as below.

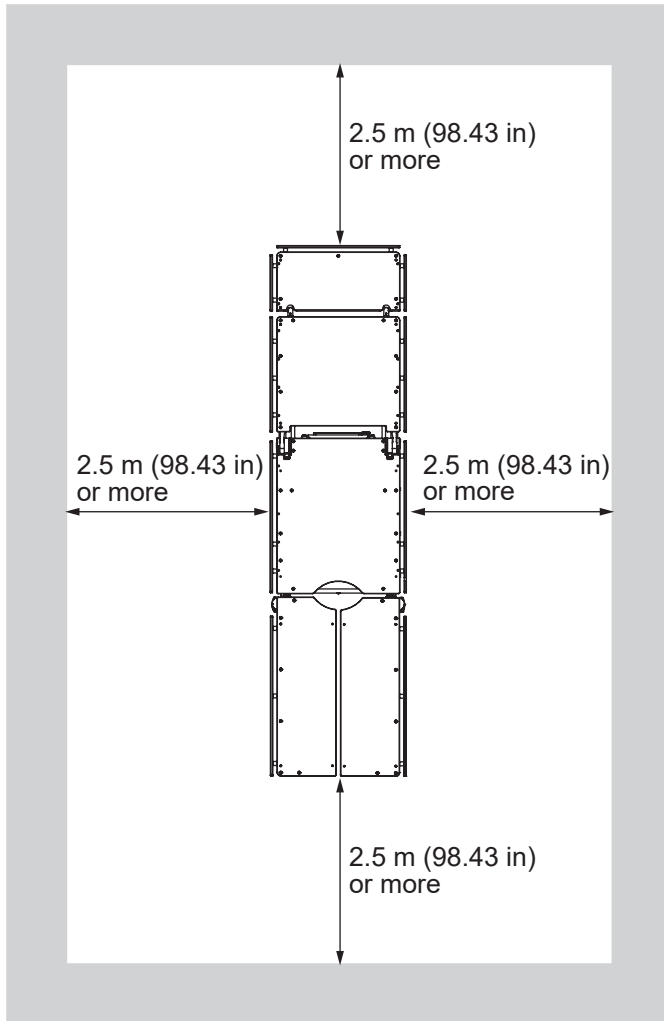

4

Operation

■ Charging the battery



- Connect the product to the power source provided with the protective grounding to prevent the risk of an electrical shock.
- Make sure to use the dedicated power cord with the “MIZUHO” logo.
- Before inserting the power cord into the power connector, check that the power connector does not have any fluid in it nor is dusty.
- If the battery deteriorates, it will not be available for the operating table when AC power is not supplied due to power outage etc.

NOTE

- Make sure to charge the battery when initially using the purchased product, or when it has not been used for a long time. The battery naturally discharges itself when it is not being used and is being stored.
- If the battery lamp on the hand controller flashes or the battery indicator on the lower part of the operating table lights up only red while using the operating table with the battery power, charge the battery immediately. When the battery is discharged, only the AC power is available and will not be able to use the battery power.
- The operating table battery replacement time is about 2 years. Once it reaches its replacement time, request your distributor or Mizuho for a battery replacement.
- The life-span for the battery varies greatly depending on operating conditions. The battery could degrade quicker if charging and discharging the battery are repeated frequently after using the operating table for short operations.
- It is recommended that you charge the battery once a week on weekends, since it takes about 17 hours to fully charge the battery.
- If the battery is discharged soon even after charging, the battery may be degraded. Request repairs from your distributor or Mizuho.
- While the battery is being charged, you can operate the operating table by using  on the hand controller.

1. Connect the power connector of the product and the medical grade outlet with the power cord.

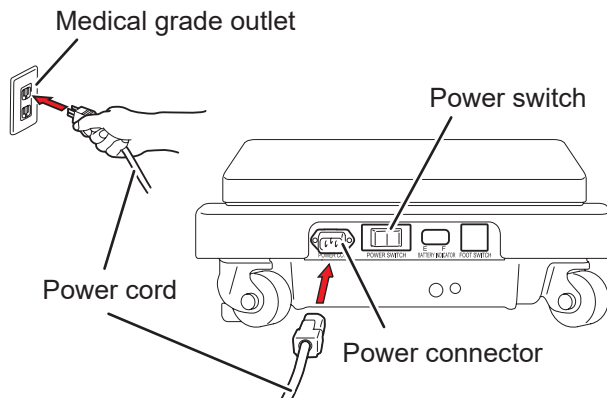

2. When turning on the power switch, battery charging starts.

While charging, the battery indicator sequentially lights up orange.

3. When the battery indicator sequentially lights up orange and green, charging is completed.

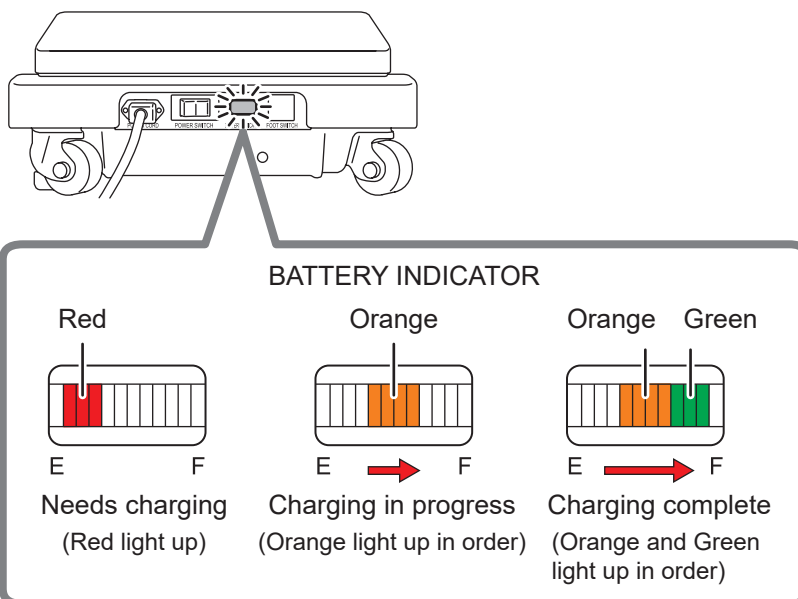

■ Attaching the hand controller

1. Align the connector with the guide and insert it into the receptacle properly.

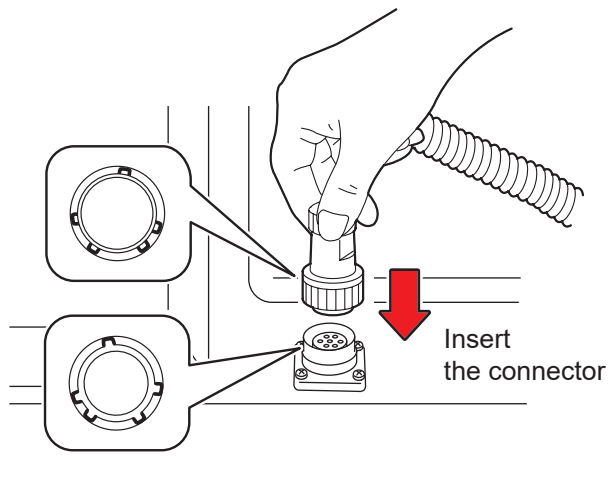

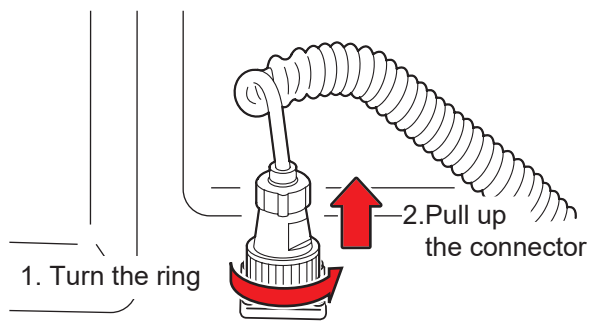

■ Detaching the hand controller

1. Turn the connector ring in the direction of the arrow until it stops.
2. Once it stops, pull up the connector.



■ Using the self-diagnostic function

This product is equipped with an embedded self-diagnostic function capable of checking the communication status between the main unit and the hand controller.

- 1. Connect the power connector of the product and the medical grade outlet with the power cord.**
- 2. Press  on the hand controller.**
- 3. Press  and one of the function switches on the hand controller at the same time.**

If two lines of green on the battery indicator light up, the hand controller is functioning properly.

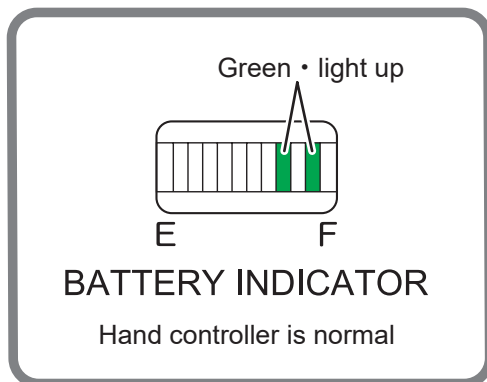

4.2 Turning on/off the power

■ When the medical grade outlet is used

● Turning on the power

1. Turn on the power switch on the base.

The power switch (green) and the battery indicator will be lighted on.

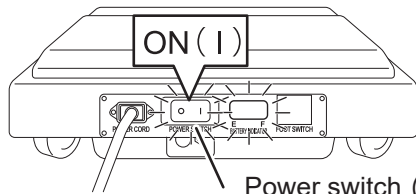

Power switch (Green • light up)

2. Press on the hand controller.

The power lamp (green) on the hand controller lights up and the power is turned on.

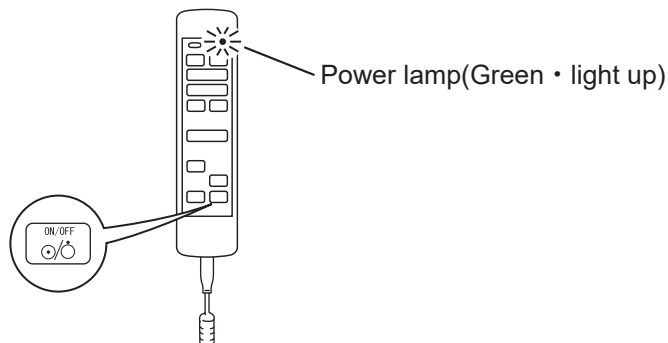

NOTE

- In an emergency or when turning off the power completely, disconnect the power cord from the medical grade outlet.
- If you press  on the hand controller before turning on the power switch on the base, the battery power will be turned on.

● Turning off the power

1. When the power is turned on, press  on the hand controller.

The power lamp (green) on the hand controller goes out.

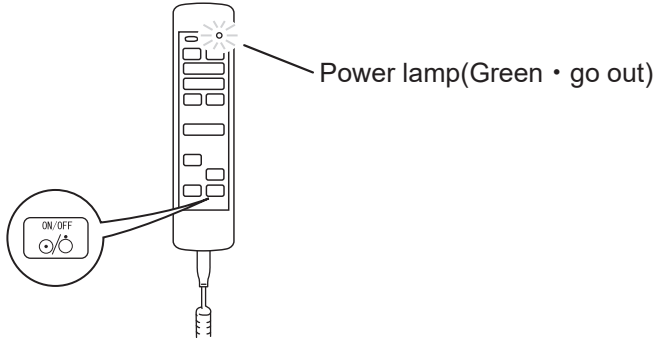

NOTE

If you turn off the power switch on the base before pressing  on the hand controller, the battery power will be turned on.

2. Turn off the power switch on the base.

The power switch (green) and battery indicator go out, and the power is turned off.

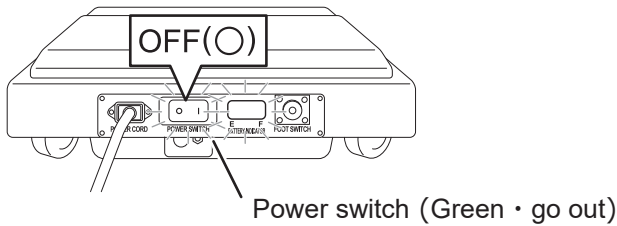

■ When the battery is used

● Turning on the power

1. When the power cord is not connected to the power connector or the power switch on the base is turned off, press  on the hand controller.

The power lamp (green) and battery lamp (orange) light up, and the power is turned on.

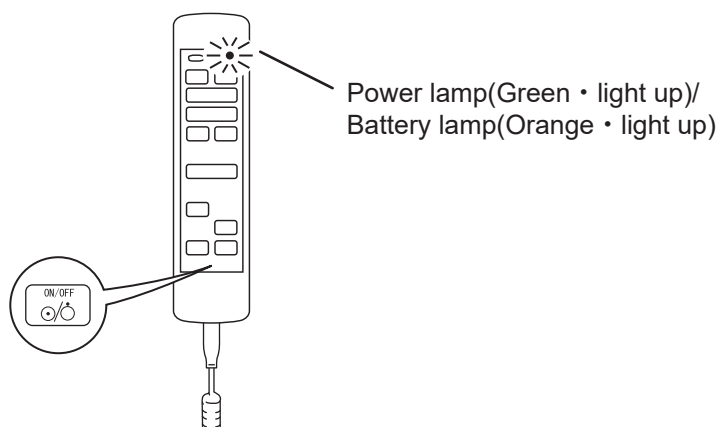
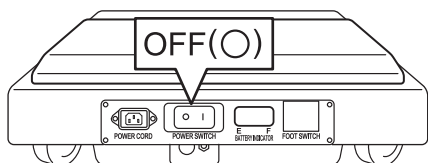

NOTE

When using the battery, the power is turned off automatically 2 hours after the last operation.

● Turning off the power

1. When the power switch on the base is turned off, press  on the hand controller.

The power lamp (green) and battery lamp (orange) go out, and the power is turned off.

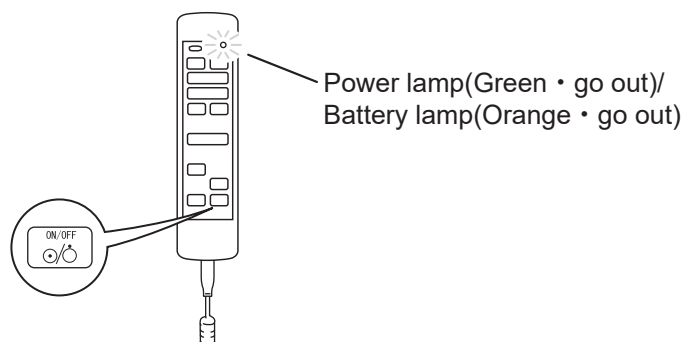

4.3 Operating the emergency stop switch

In an emergency, you can stop the operating table from moving by pressing the emergency stop switch.



The emergency stop switch must be used only in an emergency.

■ Operating in an emergency

1. Press the emergency stop switch.

The buzzer sounds and the operating table stops.

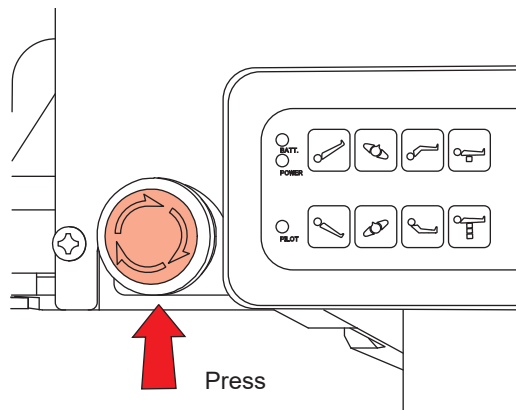

NOTE

The emergency stop switch is located at the left side of the auxiliary switch.

■ Canceling operations



To reset the operating table to the original position in an emergency where, for example, an operator's hand is caught in a gap of the operating table, press the switch on the hand controller to move the table in the opposite direction.

1. After the operating table stops, turn the emergency stop switch in the direction of the arrow or pull it forward to cancel the emergency stop switch.

The buzzer stops sounding.

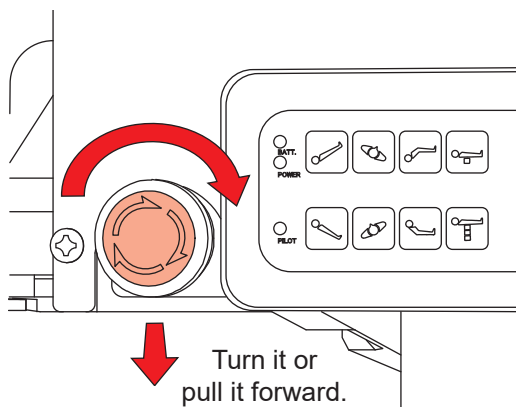

4.4 Fixing and unfixing the operating table

Fixing the operating table





- After activating the brake, check that the operating table is fixed securely.
- If the operation needs to be halted, press the emergency stop switch.

1. Press first and then .

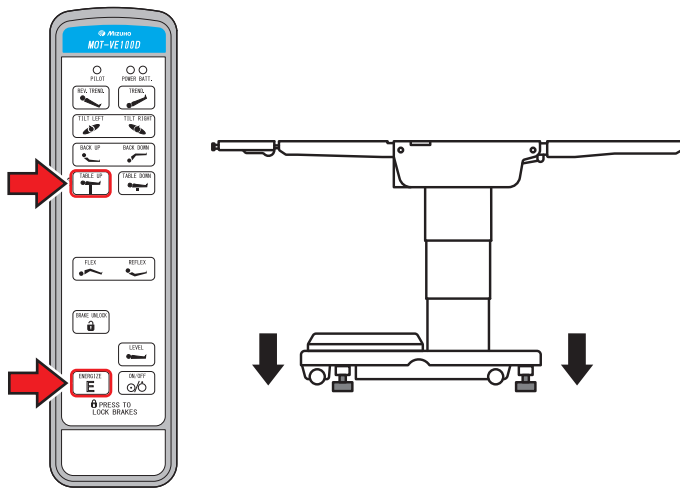
The brake is activated to fix the operating table. Operations such as raising the tabletop will not operate until the fixing of the operating table is completed.



NOTE

- The operating table can be fixed or unfixed once  and  or  are pressed.
- It takes about 12 seconds until the operating table is fixed or unfixed.
- If the brake cannot be activated and the operating table is not fixed, refer to “Troubleshooting.” (→ Page 46)

Unfixing the operating table



- Do not unfix the operating table with a patient on it. The patient may fall from the operating table.

1. Press first and then for 1 second or more.

The brake is released for unfixing the operating table. The operating table can be moved.

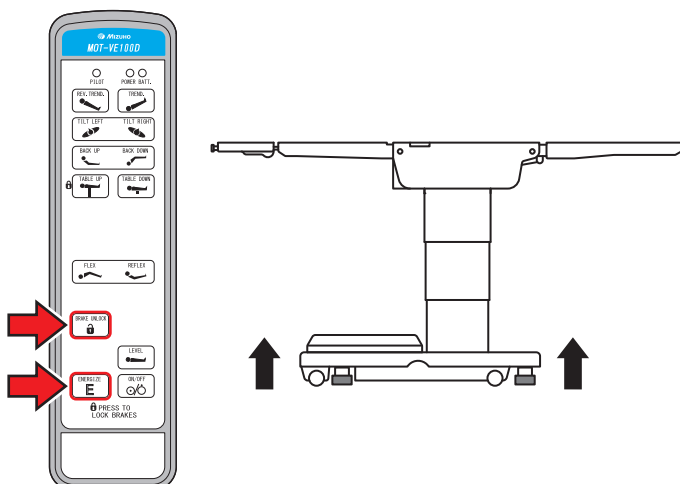

4.5 Tilting the tabletop laterally



When you tilt the tabletop laterally with a patient on the operating table, make sure to use the fixing accessory for the Mizuho operating table. The patient may fall from the operating table.

■ Tilting to the left

1. Press  first and then .

The tabletop tilts to the left in the view from the head side.

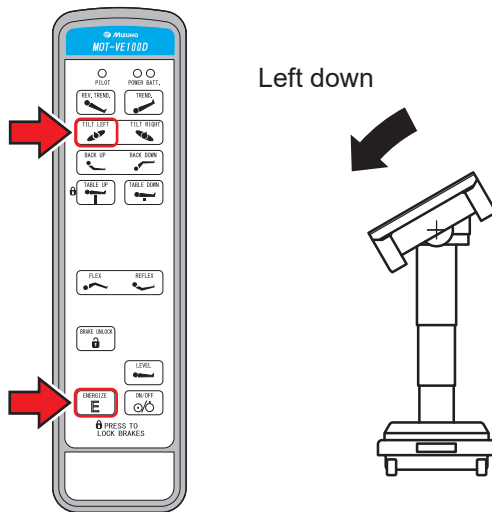

NOTE

- The maximum angle achieved in the left down position is 20° from the level position.

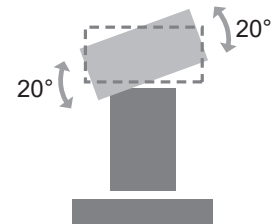

- When lateral tilt is operated in the opposite direction from the current lateral tilt position, it will stop in the level position. Once it stops, release the switch and press it once again; it will be laterally tilted to the maximum angle.

■ Tilting to the right

1. Press  first and then .

The tabletop tilts to the right in the view from the head side.

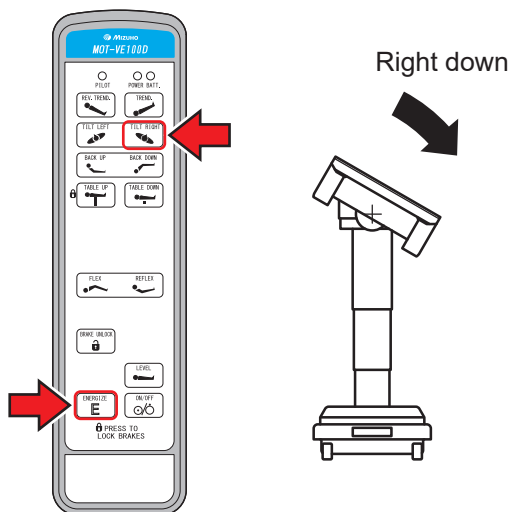

NOTE

The maximum angle achieved in the right down position is 20° from the level position.

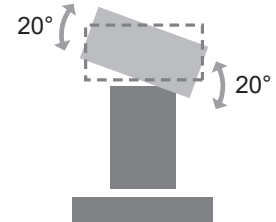

4.6 Trendelenburg



When you operate the Trendelenburg operation with a patient on the operating table, make sure to use the fixing accessory for the Mizuho operating table. The patient may fall from the operating table.

■ Reverse Trendelenburg (Head up)



- Do not operate until the tip of the leg section contacts the floor. It may get damaged.
- Do not operate reverse Trendelenburg position with the leg section bent down. The tip of the leg section may come in contact with the base and get damaged.

1. Press  first and then .

The tabletop moves to the head up position.

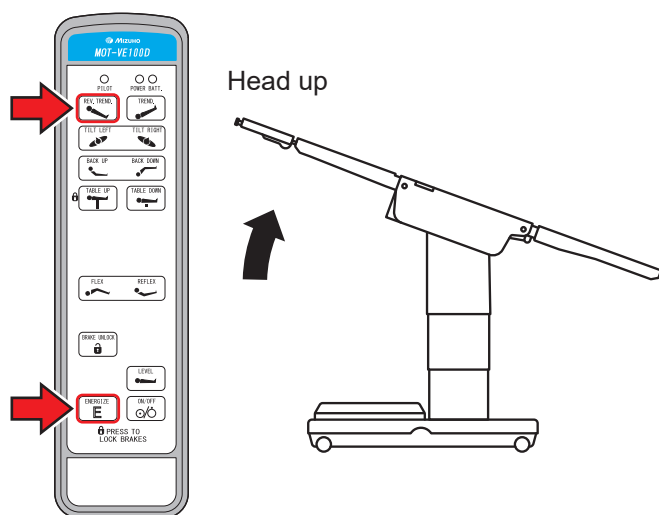

NOTE

- The maximum angle achieved in the head up position is 30° from the level position.
- 
- When Trendelenburg is operated in the opposite direction from the current Trendelenburg position, it will stop in the level position. Once it stops, release the switch and press it once again; it will be tilted to the maximum angle.

■ Trendelenburg (Head down)



- Do not operate until the tip of the head section contacts the floor. It may get damaged.
- Do not operate until the head section fixing handle contacts the base. It may get damaged.

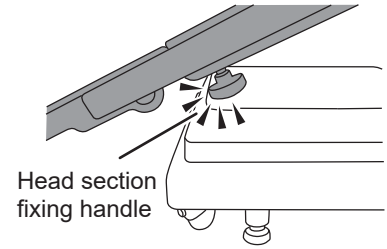

1. Press  first and then .

The tabletop moves to the head down position.

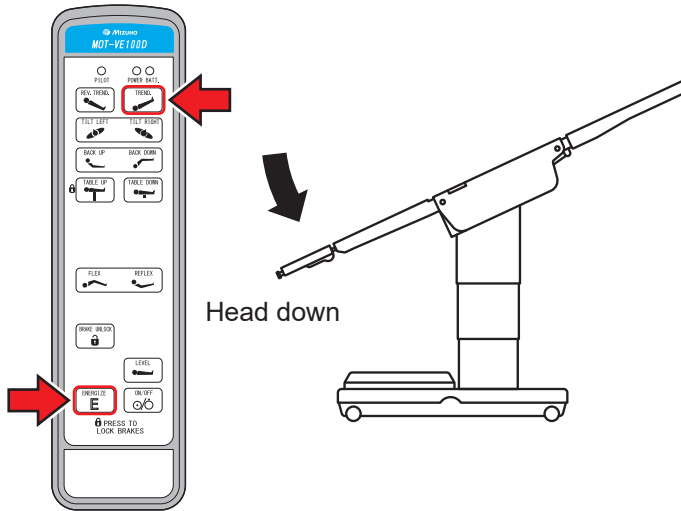

NOTE

The maximum angle achieved in the head down position is 30° from the level position.

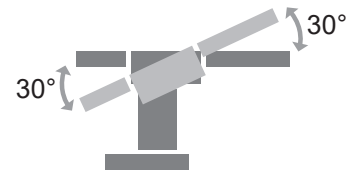

4.7 Back section up/down



Keep your hands away from the following gap during the operation of the table. Otherwise you may get injured.

- Gap between the back section and seat section
- Gap between the back section gear and rack

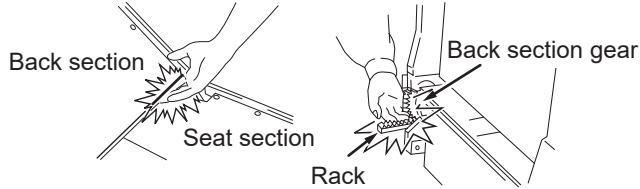

4

Operation

■ Moving up the back section

1. Press first and then .

The back section moves up.

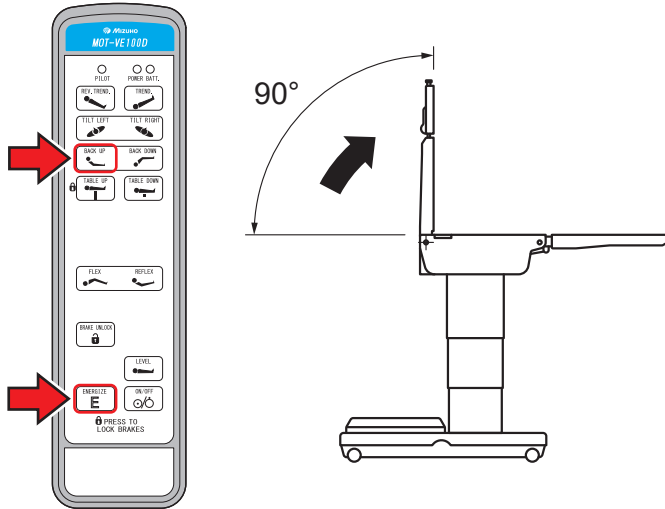

NOTE

- The maximum angle achieved in the back section up position is 90° from the level position.
- The maximum angle achieved in the back section down position is 40° from the level position.
- When the back section is tilted in the opposite direction from the current tilted back section position, it will stop in the level position. Once it stops, release the switch and press it once again; it will be tilted to the maximum angle.

■ Moving down the back section

1. Press first and then .

The back section moves down.

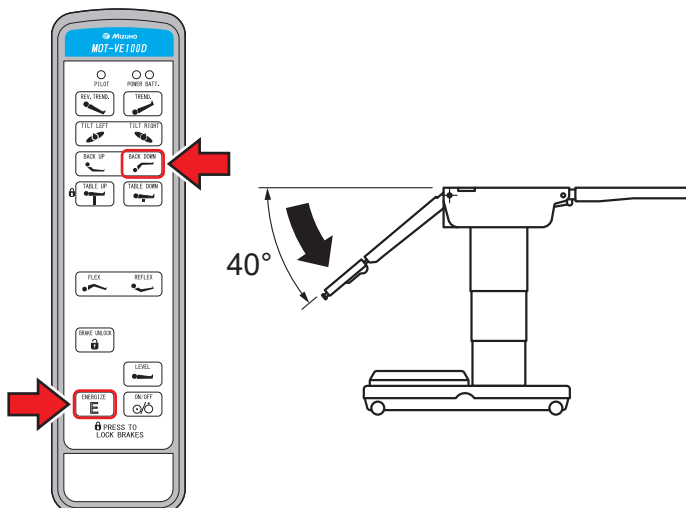

4.8 Changing the tabletop height



- Do not move down the tabletop with the leg section bent down at 90°. The tip of the leg section may come in contact with the floor or the base and get damaged.
- Do not operate until the tip of the leg section contacts the floor when moving down the tabletop with the leg section bent down. It may get damaged.

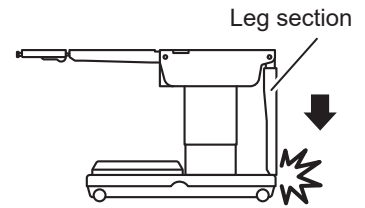

■ Moving up the tabletop

1. Press  first and then .

The tabletop moves up.

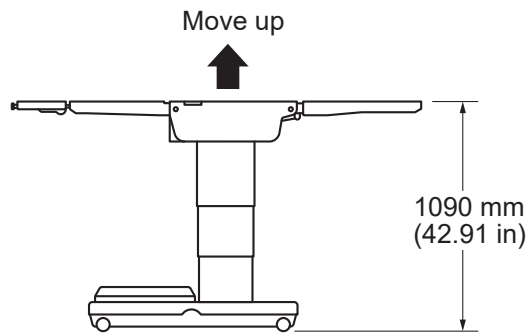
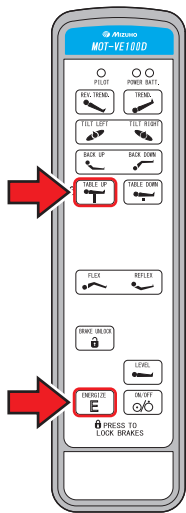

NOTE

- The maximum height from the floor to the tabletop upper surface is 1090 mm (42.91 in).
- The minimum height from the floor to the tabletop upper surface is 635 mm (25.0 in).

■ Moving down the tabletop

1. Press  first and then .

The tabletop moves down.

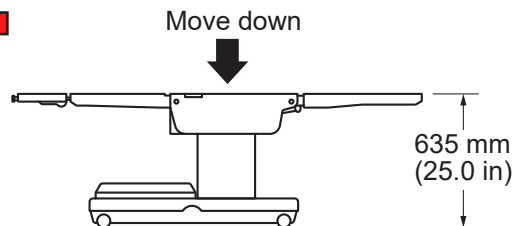
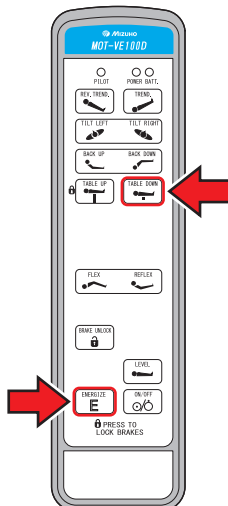

4.9 Flexing or reflexing the tabletop



WARNING

Keep your hands away from the following gap during the operation of the table. Otherwise you may get injured.

- Gap between the back section and seat section
- Gap between the back section gear and rack

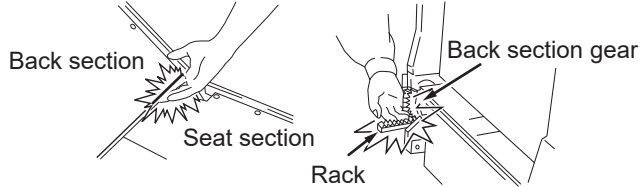

4

Operation

■ Flexing the tabletop



CAUTION

Do not flex the tabletop with the leg section bent down. The leg section may come in contact with the floor and get damaged.

1. Press  first and then  .

The back section bends downward and the seat section turns to the reverse Trendelenburg (head up) position.

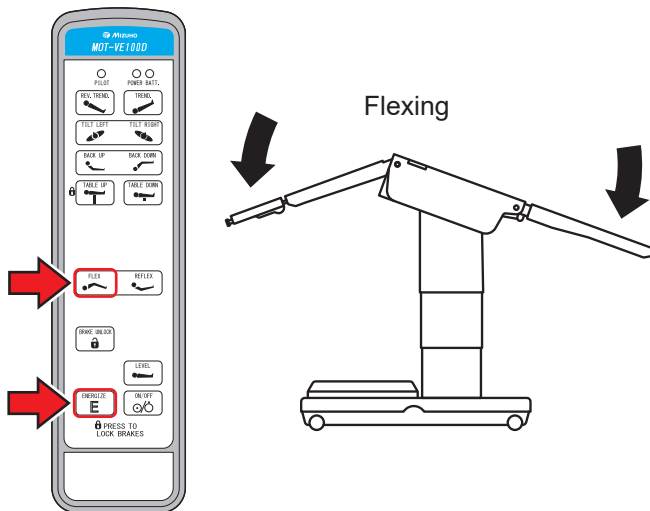

■ Reflexing the tabletop

1. Press  first and then  .

The back section bends upward and the seat section turns to the Trendelenburg (head down) position.

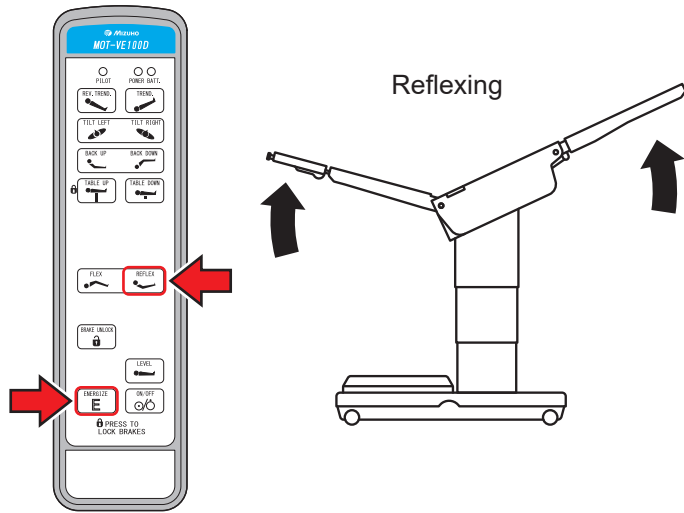

4.10 Return to level

■ Return the tabletop to the level position

1. Press  first and then .

The tabletop from the Trendelenburg, lateral tilting, back section up/down and flexing will return to the level position.

NOTE

Elevation and braking do not function.

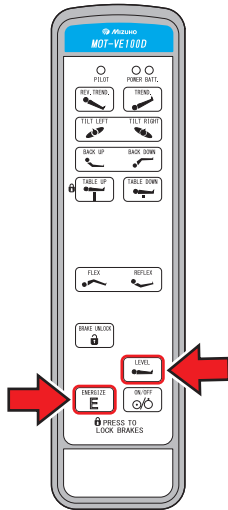

4.11 Adjusting the head section

The head section can be bent in 15° increments, to 4 different positions upward (maximum 60°) and to 6 different positions downward (maximum 90°). The head section can also be detached.



The head section weighs 7 kg (15.4 lbs). Pay special attention when handling it. It may drop and cause damage or injury.

■ Head section up/down

1. Pull the head section flexing lever toward the head direction. The head section can be bent upward and downward. When releasing the lever, the head section is fixed in that position.

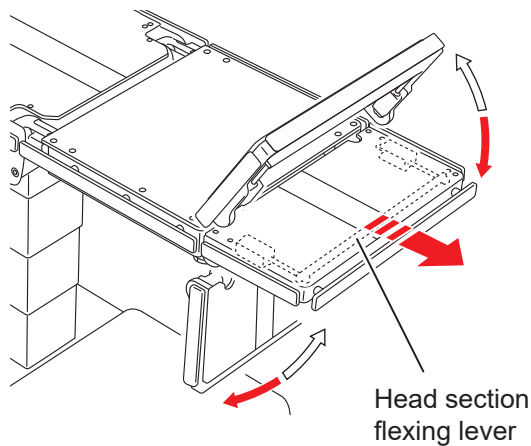

NOTE

When bending upward, the head section can be lifted and bent without pulling the head section flexing lever.

■ Detaching the head section

1. Loosen the two head section fixing handles located on the lower side of the back section.
2. Hold both sides of the head section firmly and pull straight.

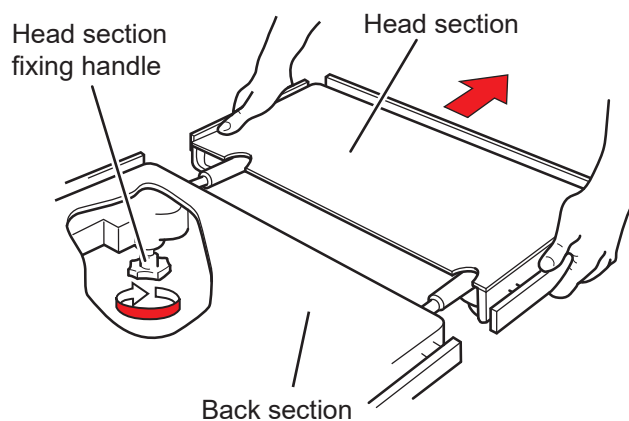

■ Attaching the head section



Make sure to tighten the head section fixing handles securely. If the head section moves with the handles in a loosened state, the patient may get injured.



- Make sure to insert the head section into the back section completely. If the operating table is used with the head section inserted incompletely, it may get damaged.
- Do not move the operating table by pulling on the head section. It may drop and cause damage or injury.

- 1. Hold both sides of the head section firmly and align the head section insertion shafts with the back section reception holes, and insert.**
- 2. After checking that the head section is completely inserted, tighten the two head section fixing handles located on the lower side of the back section to fix it.**

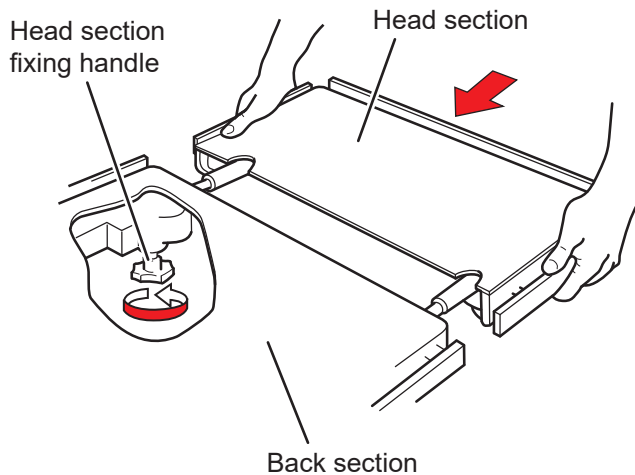

4.12 Adjusting the leg section

The leg sections can be bent, stretched outward, and detached.



The leg section weighs 8 kg (17.6 lbs) (each). Pay special attention when handling it. It may drop and cause damage or injury.

■ Leg section up/down

The right and left leg sections can be bent independently in 15° increments, to 6 different positions downward (maximum 90°).



Make sure to hold the tip of the leg section when bending. Otherwise the leg section may bend down by its own and cause injury.



- Do not operate reverse Trendelenburg position with the leg section bent down. The tip of the leg section may come in contact with the base and get damaged.
- Do not operate until the tip of the leg section contacts the floor when moving down the tabletop with the leg section bent down. It may get damaged.

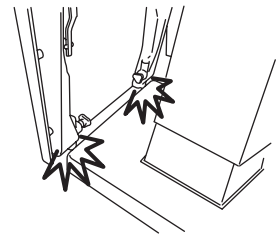

- 1. Hold the tip of the leg section, then pull the leg section flexing lever toward the foot end while lifting up the tip of the leg section a little to release the lock.**
- 2. Push the leg section downward while the leg section flexing lever is pulled out toward the foot end.**
- 3. To reset the leg section to the level position, hold and bring up the tip of the leg section.**

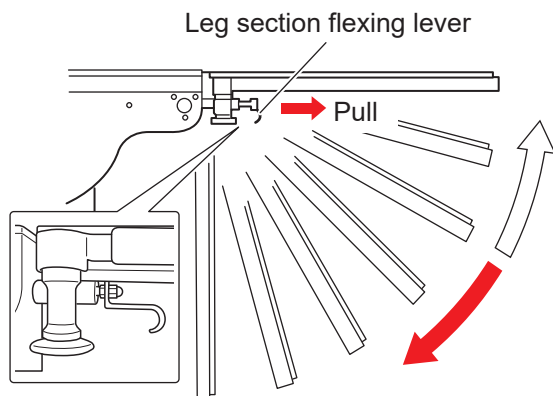

■ Outstretching the leg section

The leg sections can be stretched outward up to 90°.



- Keep your fingers from in between the rails while outstretching the leg section. Otherwise you may get injured.
- Make sure to tighten the leg section fixing handles securely. If the leg sections move with the handles in a loosened state, the patient may get injured.

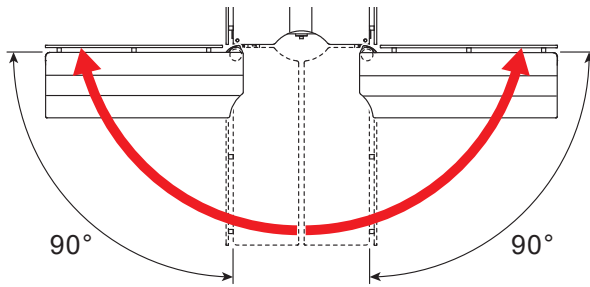

- 1. Hold the tip of the leg section on the leg side and turn the leg section fixing handle 1 revolution and a half to loosen it.**
- 2. Pull the leg section outward.**
- 3. At the setting position, tighten the leg section fixing handle to fix the leg section.**

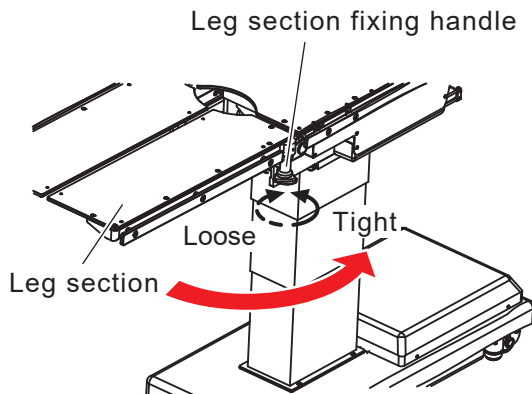

NOTE

Loosening the leg section fixing handle more than is required may cause the leg section to come off upward. If the leg section comes off, attach the leg section via the following method.

1. Hold the leg section firmly and align the leg section insertion shaft (outstretching part) with the leg section clutch, and insert.
2. Hold the tip of the leg section on the leg side and turn the leg section fixing handle until it engages with the leg section clutch to fix.

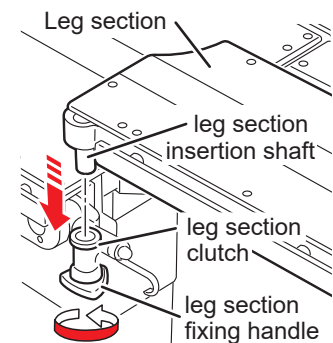

■ Detaching the leg section

1. Hold the tip of the leg section on the leg side and turn the leg section attaching/detaching handle to loosen it.
2. Hold both sides of the leg section firmly and pull it straight out.

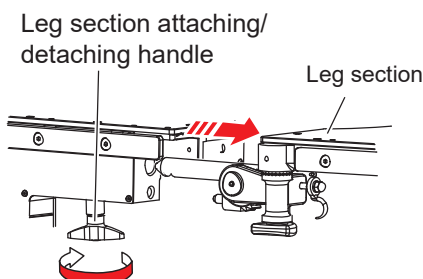

NOTE

The handgrip can be changed to any direction by turning the leg section attaching/detaching handle while pulling it downward.

■ Attaching the leg section



WARNING

Make sure to tighten the leg section attaching/detaching handles securely. If the leg sections move with the handles in a loosened state, the patient may get injured.



CAUTION

Make sure to insert the leg section into the reception holes completely. If the operating table is used with the leg section inserted incompletely, it may get damaged.

1. Hold both sides of the leg section firmly and align the leg section insertion shaft with the leg section reception hole, and insert.
2. After checking that the leg section is completely inserted, tighten the leg section attaching/detaching handle to fix the leg section.

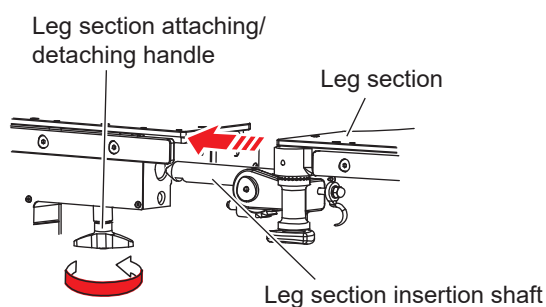

5. Maintenance and inspection

5.1 Inspection before and after use



Make sure to inspect the items below before and after use. If there are any abnormalities, request your distributor or Mizuho for repairs. Otherwise it may cause problems during surgery.

Inspect the items below. If there is any problem, request your distributor or Mizuho for repair.

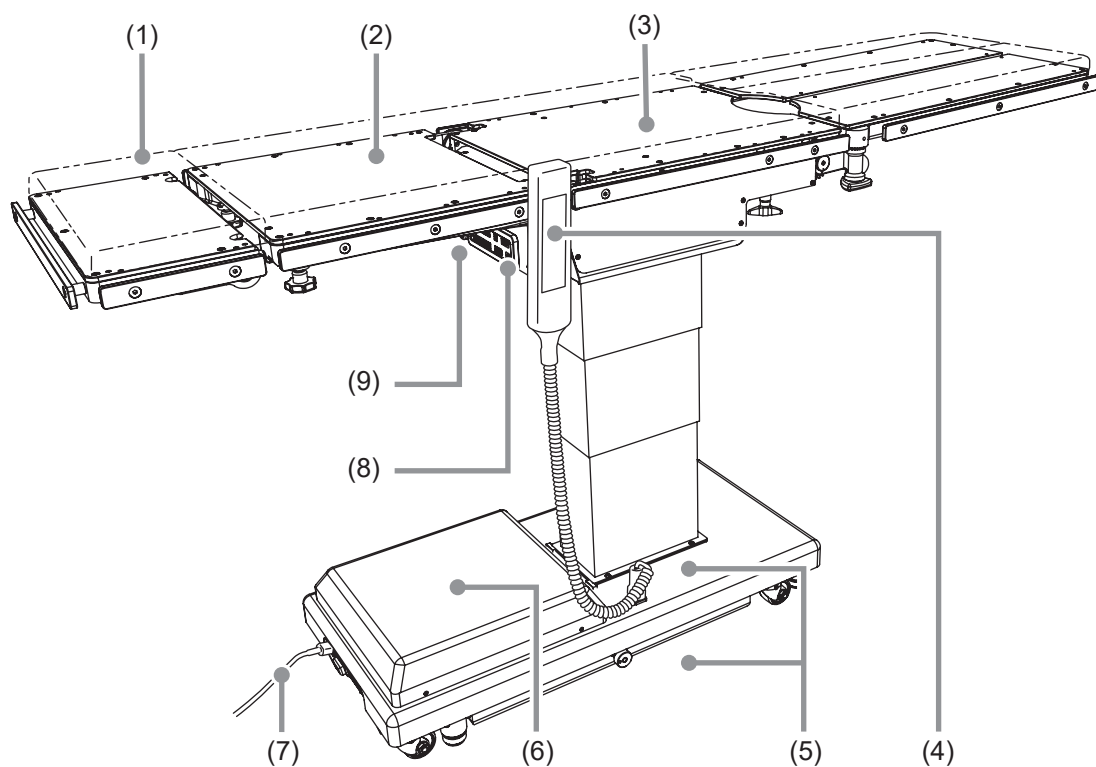

(1) Table pads

● Before use

- Check all the table pads for any damage.

● After use

- Check all the table pads for any damage or dirt.

(2) Backlash of the tabletop

● Before use

- Check all the tabletops for any backlash when jiggling both sides of the back section.

(3) Tabletops

● Before use

- Check all the tabletops for any damage.

● After use

- Check all the tabletops for any damage or dirt.

(4) Hand controller

● Before use

- Press the power ON/OFF switch on the hand controller to see if the power lamps on the hand controller light up.
- Press the switches on the hand controller to see if all functions are working properly.

(5) Oil leakage

● Before and after use

- Check the floor or the base surface for any hydraulic oil.

(6) Battery

● Before use

- Check if the battery has been charged.

(7) Power cord and plug

● Before use

- Check the power cord for any exposed wire and the plug for any damage.

(8) Auxiliary switch

● Before use

- Press the auxiliary switch to see if all functions are working properly.

(9) Emergency stop switch

● Before use

- Check if the emergency stop switch is working properly.

5.2 Cleaning and disinfection



WARNING

- In order to prevent infections, make sure to clean and disinfect the operating table after using it.
- Make sure to unplug the power cord and turn off the main power when cleaning and disinfecting the operating table. The operating table may actuate and cause injury.



CAUTION

- Make sure to use Mizuho authorized disinfectants. Failure to do so may cause the operating table to become discolored or deformed.
- When cleaning the table pads, take care not to get liquids on the fasteners. If liquids get on the waterproof fasteners, wipe them off quickly. If the waterproof fastener gets wet and the liquids infiltrate inside, it may cause degradation.

■ Cleaning and disinfection procedures

1. Turn off the power and disconnect the power cord from the medical grade outlet.
2. Detach all the table pads from the operating table.
3. Use a lint-free cloth soaked with proper volume of disinfectant to wipe off the upper, sides, and back side of the table pads.
4. As with step 3, disinfect the surfaces of the tables and side rails.
5. Wipe off the operating table with a clean dry cloth within 15 minutes after disinfecting it.

■ Disinfectants

Authorized disinfectants are as shown below.

	Disinfectant name	Concentration
a	Sodium hypochlorite	0.1%
b	Hypo Alcohol	10%
c	Chlorhexidine gluconate	0.5%
d	Benzalkonium chloride	10%
e	Ethanol	80%
f	Isopropyl alcohol	99.5%

NOTE

Use the disinfectant according to the operator's manual and instructions for disinfectant use.

5.3 Maintenance by providers

For safety use of this product, make sure to perform the periodical inspection by Mizuho or the certified provider once a year.

Inspections and maintenances by other than Mizuho or the certified provider could cause any adverse event such as deterioration of the performance and functions.

For request for the periodical inspection, contact your distributor or Mizuho.

5.4 Periodic replacement parts

Mizuho specifies that the following parts need to be periodically replaced for safety use.

The replacement time is a rough standard. Earlier replacement may be required depending on the usage condition and/or usage frequency.

Request your distributor or Mizuho for replacements.

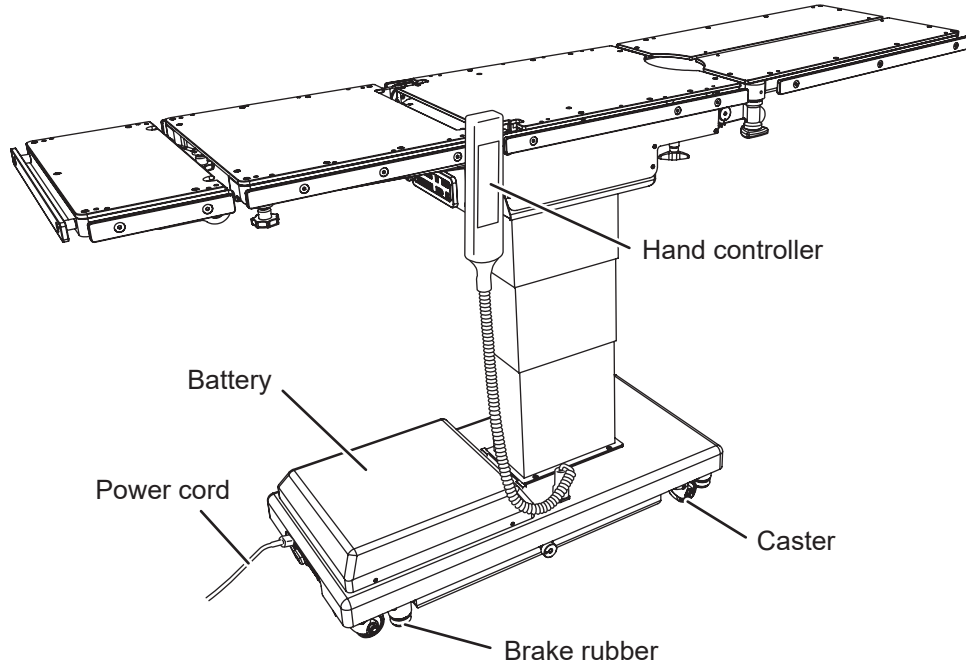

Parts	Replacement time (years)
Battery	2
Hand controller	4 to 6
Caster	5 to 7
Brake rubber	3 to 5
Power cord	5 to 7

NOTE

The aforementioned are estimated times. The replacement time may depend on usage condition and/or usage frequencies.

5.5 Version information of the software

The version information for the control software which is installed in the operating table can be verified via the label that is directly applied on the on-board microcomputer.



The version information of the software is mainly for the service and maintenance personnel as needed. For confirmation, open the base cover to access the control board.

6. Specification

6.1 Specification table

Product description			MOT-VE100
Electromotive functions	Elevation range	Highest	1090 mm (42.91 in)
		Lowest	635 mm (25.0 in)
	Trendelenburg angle	Head up	30°
		Head down	30°
	Lateral tilt angle	Left down	20°
		Right down	20°
	Back section up/down angle	Up	90°
		Down	40°
	Flexing	Flexing / Reflexing	
	Return to level	Trendelenburg, Lateral tilt, Back section up/down, Flexing	
Brake	Lock / Unlock		
Control devices	Hand controller	Elevation, Trendelenburg, Lateral tilt, Back section up/down, Flexing, Return to level, Brake, E switch, Power ON/OFF	
	Auxiliary switch	Elevation, Trendelenburg, Lateral tilt, Back section up/down, Flexing, Return to level, Brake, E switch, Power ON/OFF	
	Emergency stop switch	Stop	
Manual functions	Head section up/down angle	Up	60°
		Down	90°
	Leg section up/down angle	Up	0°
		Down	90°
	Leg section outstretching angle	Each for left and right	90°
	Detachment	Head section / Leg section (left/right)	
Others	Emergency brake release knob		
Rating	Classification as per 60601-1		Class 1 device / B type Device / IPX4 (internal power source device: Note 1)
	Supply voltage		AC 100 - 240 V
	Rated supply frequency		50/60 Hz
	Battery power		DC 24 V
	Battery charging time		Up to 17 hours (cumulative operation time when fully charged: up to 60 min.): Note 11
	Power consumption		400 VA
	Operating voltage		DC 5 V , 24 V
	Duty cycle (per 1 cycle)		3 min on, 20 min off: Note 2
Others		Recovery from defibrillator is within 5 seconds. Conformity to EMC Standard IEC 60601-1-2: 2020	
Dimension	Tabletop		2133 mm (83.98 in) (L) x 500 mm (19.69 in) (W): Note 3
	Base		1033 mm (40.67 in) (L) x 483 mm (19.02 in) (W): Note 4
Weight			360 kg (793 lbs)

Weight capacity: Note 8		Elevation: 250 kg (555 lbs) Operations other than elevation: 250 kg (555 lbs)
Transitable height and width		Height: 10 mm (0.39 in) / Width: 80 mm (3.15 in)
Table pad		Anti-defibrillation device
		Flame resistance: BS 7177 Fire Test on Mattresses, Sofas and Bases Classification: Conforms to BS 7177:2008 for medium hazard (Medium Hazard [5])
		Manufacturing method via waterproofing: Welder processing: Note 9 Waterproof fasteners: Note 10
Operating environment	Temperature	10 to 40°C (50 to 104°F): Note 7
	Humidity	30 to 75%: Note 7
	Atmospheric pressure	700 to 1060 hPa: Note 7
	Others	Allowable altitude for use is 3000 m or lower.: Note 7
Transportation and storage	Temperature	-10 to 50°C (14 to 122°F): Note 5
	Humidity	10 to 85% (without moisture condensation): Note 5
	Atmospheric pressure	700 to 1060 hPa: Note 5
Service life		Under the specified maintenance and proper storage, 10 years: Note 6

Note 1: When the battery power is used

Note 2: Operating tables operating possible time and halting time per 1 cycle

Note 3: Excluding the side rail

Note 4: Rough dimension

Note 5: Company standard (in case that appropriate maintenance and inspection is done)

Note 6: Based on Mizuho's own validation data

Note 7: IEC 60601-1: 2020 Medical electrical equipment - Part1: General requirements for basic safety and essential performance

Note 8: Total of the patient and accessories

Note 9: Process that seamlessly welds via heat

Note 10: Fastener with high waterproofness

Note 11: Depending on the usage conditions

6.2 External view

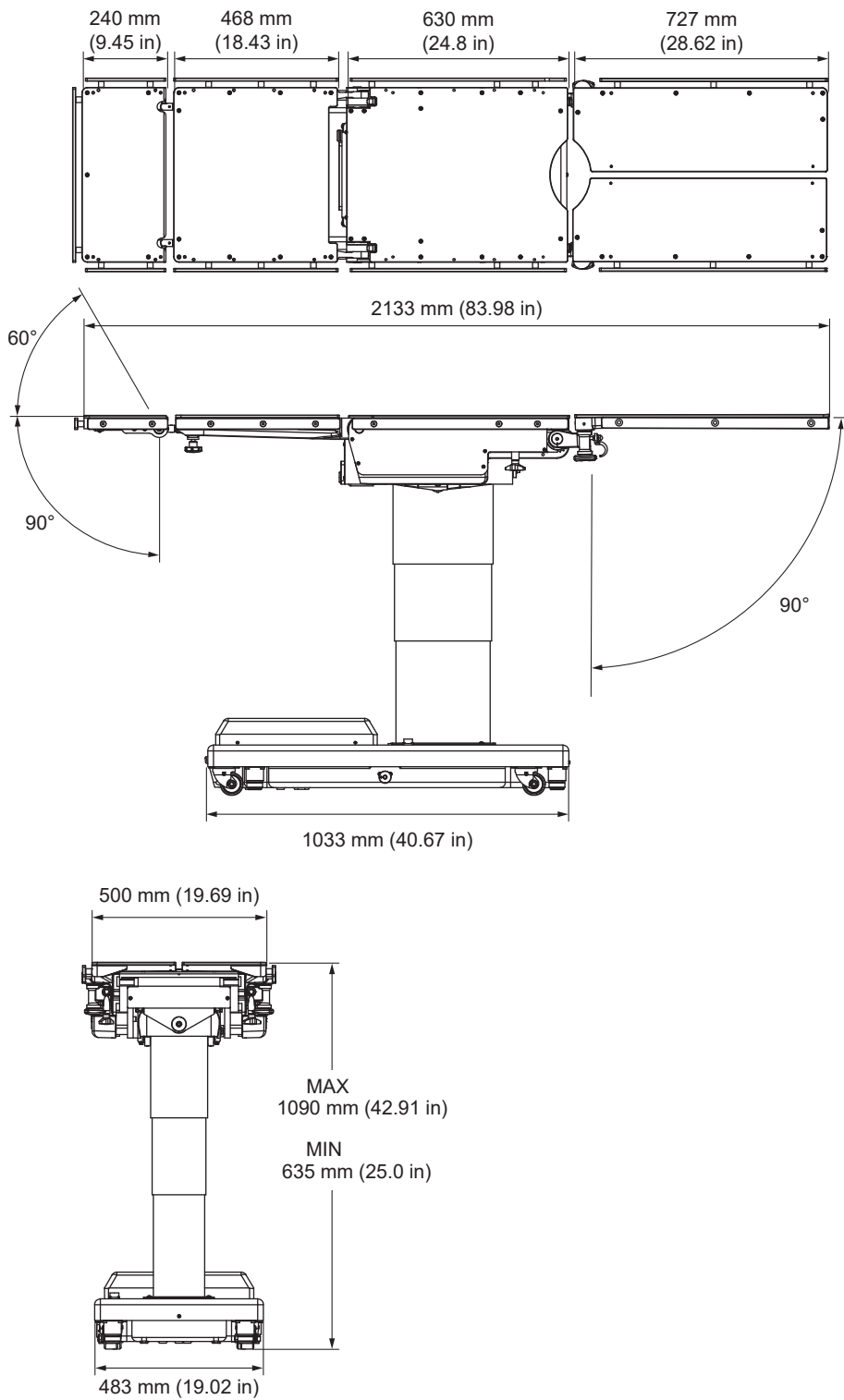

7. Troubleshooting

7.1 When the hand controller cannot be used

■ Use the auxiliary switch to operate the operating table



- The auxiliary switch should be used only in an emergency.
- Always watch movement of the operating table when you operate the auxiliary switch.
- If any parts come in contact with each other, immediately stop the operation. Otherwise, the operating table may get damaged.

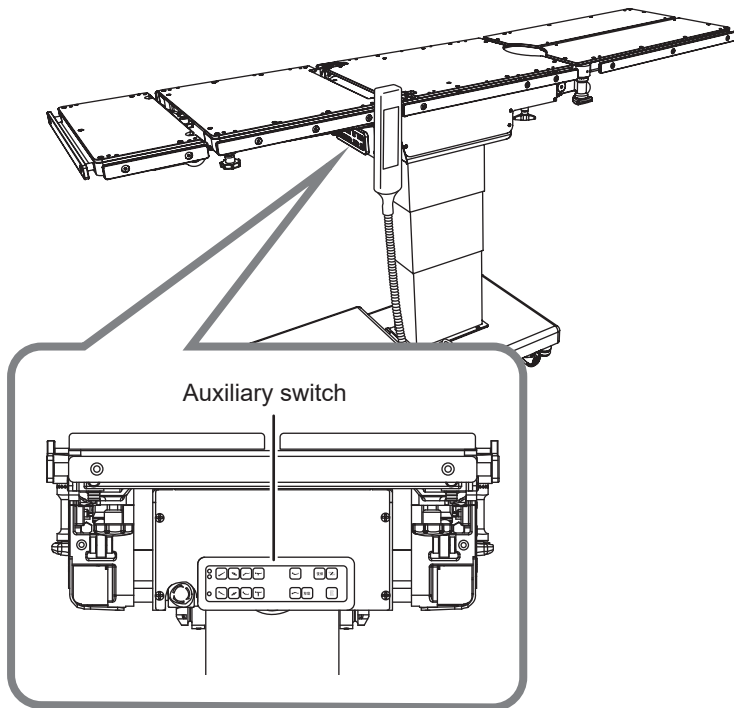

1. Press  first and then the function switch.

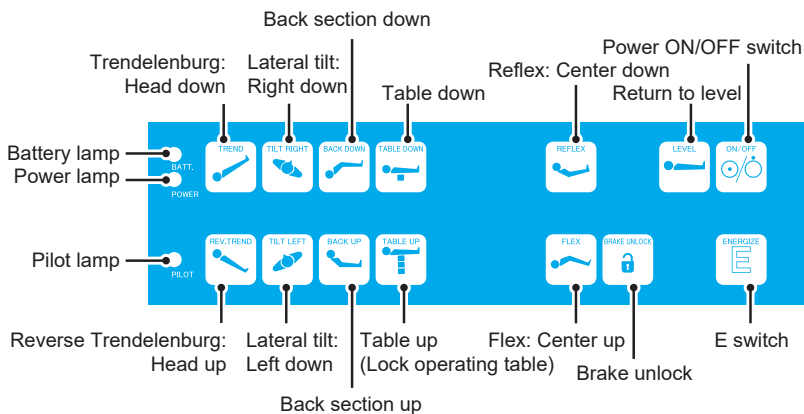

NOTE

- If  is pressed, the pilot lamp lights up. Pressing any function switch while the pilot lamp is lighting up, that function will operate while the switch is pressed.
- The operating table stops once the maximum angle is achieved at each operation.

7.2 When the brake cannot be released



- Do not operate the emergency brake release knob with a patient on the operating table. The operating table may tip over resulting in injury.
- Do not operate the operating table while the emergency brake release knob is in the UNLOCK state. The operating table may tip over resulting in injury.
- After returning the emergency brake release knob to LOCK, operate the brake release with the hand controller. If the operating table is operated without the brake release being operated, the system misidentifies the operating table is locked properly and the operating table operates with the brakes released, which may tip over resulting in injury.

■ Brake release with the emergency brake release knob

In case of electrical trouble, the operating table can be moved by using the emergency brake release knob.

Follow the procedure below to release the brake.

1. Turn the emergency brake release knob clockwise (to the right).

The brake on the operating table body will be released.

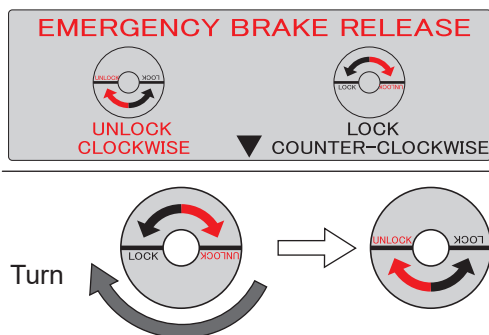

■ Brake release and fixing the operating table

When you want to use it again after the electrical trouble been fixed, follow the procedure below to release the brake and fix the operating table.

1. Turn the emergency brake release knob counterclockwise (to the left).

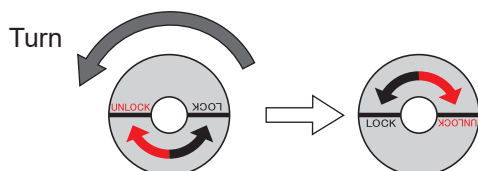

2. Press first and then on the hand controller for 1 second or more.

The operating table system recognizes the brake release status.

3. Press first and then on the hand controller.

The operating table will be fixed.

8. Before contacting for repairs

■ Checking causes and countermeasures

The following problems can occur even if the operating table is not malfunctioning. Check the following points before requesting repairs.

Status	Possible cause	Measures
The table cannot be turned on.	The connector of the hand controller is not connected properly.	Insert the connector completely. (→Page 18)
	The battery may be low.	Charge the battery. (→Page 17)
A function switch on the hand controller does not function.	The connector of the hand controller is not connected properly.	Insert the connector completely. (→Page 18)
	You did not press the E switch before the function switch.	Press E switch first and then the function switch. (→Page 24 to 32)
	Motor may be overheated.	Wait for about 90 minutes to operate. (→Page 14)
The operating table cannot be fixed.	The emergency brake release knob is in "UNLOCK" position.	Turn the emergency brake release knob toward "LOCK." (→Page 46)
	After releasing the brake by the emergency brake release knob, the brake has not been unlocked by the hand controller.	Unlock the brake by the hand controller. (→Page 46)
The battery indicator is flashing red.	The battery is fully charged.	1. Unplug the power cord, then after operating the elevation function with battery power, turn the power switch back on. (→ Page 22, 29)
		2. Turn off the power switch, then after operating the elevation function with battery power, turn the power switch back on. (→ Page 22, 29)
	If the situation does not improve even if countermeasures 1. and 2. are implemented.	
	The battery's fuse is blown.	Request repairs from your distributor or Mizuho.

If the situation does not improve even if the above countermeasures are implemented, request repairs from your distributor or Mizuho.

■ In case of malfunction



- The operating table should only be serviced or maintained by Mizuho or the certified providers. Make sure to contact your distributor or Mizuho for maintenance or repairs.
 - Do not disassemble the operating table. Unauthorized disassembling may cause a fire, electrical shock or malfunction.
 - In order to prevent infections, make sure to clean and disinfect the operating table when requesting to have it repaired.
-

Implement the follow measures when the operating table malfunctions.

- 1. Turn off the power and disconnect the power cord from the medical grade outlet.**
- 2. Place an “Out of Order” or “Do Not Use” sign on the operating table.**

■ Warranty

MIZUHO Corporation will repair defective parts of this product without charge for one year from the date of delivery/installment except for cases of damage caused by a third party’s repair, act of nature, improper use or intentional damage. All other warranty terms and conditions are subject to regulations of MIZUHO Corporation.

App.-1 Electromagnetic Compatibility

Install and operate according to the EMC information provided in this manual.



- Do not use any accessories other than those specified by Mizuho. This can result in increased emissions and reduced immunity.
- Do not use it adjacent to or stacked with other equipment. Normal operation may not be possible due to electromagnetic interference.
- Before using other medical electronic devices (especially life support devices) to be used together, make sure that they will not malfunction due to electromagnetic interference. Normal operation may not be possible due to electromagnetic interference.

Guidelines and manufacturer declaration – electromagnetic emissions

The MOT-VE100 is intended for use in the electromagnetic environment specified below. The customer or user of the MOT-VE100 must ensure that it is operated in suchlike environments.

Electromagnetic interference measurements	Compliance	Electromagnetic environment – guideline
Harmonic emissions IEC 61000-3-2	Class A	The MOT-VE100 is suitable for use in all establishments, other than domestic establishments and those directly connected to the public low-voltage power supply network that supplies buildings used for domestic purposes.
Voltage fluctuations/ flicker emissions IEC 61000-3-3	Complies	
RF emissions CISPR 11	Class A	
RF emissions CISPR 11	Group 1	The MOT-VE100 uses RF energy only for its internal function. Therefore, its RF emissions are very low and are not likely to cause any interference in nearby electronic equipment.

Guidelines and manufacturer declaration – electromagnetic interference immunity

The MOT-VE100 is intended for use in the electromagnetic environment specified below.
The customer or user of the MOT-VE100 must ensure that it is operated in suchlike environments.

Interference immunity tests	IEC 60601 test level	Compliance level	Electromagnetic environment – guidelines
Electrostatic discharge (ESD) IEC 61000-4-2	± 8 kV contact discharge ± 2; 4; 8; 15 kV air discharge	± 8 kV contact discharge ± 2; 4; 8; 15 kV air discharge	Floors should be wood, concrete or ceramic tile. If floors are covered with synthetic material, the relative humidity should be at least 30%.
Electrical fast transient/burst IEC 61000-4-4	± 2 kV for power supply lines ± 1 kV for input and output lines	± 2 kV for power supply lines ± 1 kV for input and output lines	Power supply voltage quality should be that of a typical commercial or hospital environment.
Surge IEC 61000-4-5	± 0.5; 1 kV differential mode voltage ± 0.5; 1; 2 kV common mode voltage	± 0.5; 1 kV differential mode voltage ± 0.5; 1; 2 kV common mode voltage	Power supply voltage quality should be that of a typical commercial or hospital environment.
Voltage drops, short interruptions and fluctuations in power supply voltage IEC 61000-4-11	0% U_T for 0.5 cycles 0% U_T for 1 cycles 70% U_T for 25/30 cycles 0% U_T for 250/300 cycles	0% U_T for 0.5 cycles 0% U_T for 1 cycles 70% U_T for 25/30 cycles 0% U_T for 250/300 cycles	Power supply voltage quality should be that of a typical commercial or hospital environment. If the user of the MOT-VE100 need to continue operation during a main power interruption, it is recommended that the MOT-VE100 be powered by an uninterruptible power supply or battery.
Power frequency (50/60 Hz) magnetic field IEC 61000-4-8	30 A/m	30 A/m	Power frequency magnetic fields should be at levels characteristic of a typical location in a typical commercial or hospital environment.

Info: U_T is the AC voltage before application of the test level.

Guidelines and manufacturer declaration – electromagnetic interference immunity (continuation)

<p>Conducted disturbances induced by radiated RF IEC 61000-4-6</p>	<p>150 kHz to 80 MHz 3 V</p> <p>ISM frequencies 6 V</p>	<p>150 kHz to 80 MHz 3 V</p> <p>ISM frequencies 6 V</p>	<p>Portable and mobile RF communications equipment (radio devices, incl. antennas or cables) should be used no closer to any part of the MOT-VE100 than the recommended safety distance of 300 mm (12 in).</p> <p>The field strengths from fixed RF transmitters, as determined by field surveys of electromagnetic fields, should be less than a compliance level of 3 V/m in each frequency range.</p> <p>Interference may occur in the vicinity of equipment marked with the following symbol:</p> 																																																															
<p>Interference due to radiated RF IEC 61000-4-3</p>	<p>80 MHz to 2.7 GHz 3 V/m</p> <p>Wireless communication frequency band</p> <table border="1" data-bbox="454 593 654 1198"> <thead> <tr> <th>V/m</th> <th>MHz</th> </tr> </thead> <tbody> <tr><td>27</td><td>385</td></tr> <tr><td>28</td><td>450</td></tr> <tr><td>9</td><td>710</td></tr> <tr><td>9</td><td>745</td></tr> <tr><td>9</td><td>780</td></tr> <tr><td>28</td><td>810</td></tr> <tr><td>28</td><td>870</td></tr> <tr><td>28</td><td>930</td></tr> <tr><td>28</td><td>1720</td></tr> <tr><td>28</td><td>1845</td></tr> <tr><td>28</td><td>1970</td></tr> <tr><td>28</td><td>2450</td></tr> <tr><td>9</td><td>5240</td></tr> <tr><td>9</td><td>5500</td></tr> <tr><td>9</td><td>5785</td></tr> </tbody> </table>	V/m		MHz	27	385	28	450	9	710	9	745	9	780	28	810	28	870	28	930	28	1720	28	1845	28	1970	28	2450	9	5240	9	5500	9	5785	<p>80 MHz to 2.7 GHz 3 V/m</p> <p>Wireless communication frequency band</p> <table border="1" data-bbox="742 593 941 1198"> <thead> <tr> <th>V/m</th> <th>MHz</th> </tr> </thead> <tbody> <tr><td>27</td><td>385</td></tr> <tr><td>28</td><td>450</td></tr> <tr><td>9</td><td>710</td></tr> <tr><td>9</td><td>745</td></tr> <tr><td>9</td><td>780</td></tr> <tr><td>28</td><td>810</td></tr> <tr><td>28</td><td>870</td></tr> <tr><td>28</td><td>930</td></tr> <tr><td>28</td><td>1720</td></tr> <tr><td>28</td><td>1845</td></tr> <tr><td>28</td><td>1970</td></tr> <tr><td>28</td><td>2450</td></tr> <tr><td>9</td><td>5240</td></tr> <tr><td>9</td><td>5500</td></tr> <tr><td>9</td><td>5785</td></tr> </tbody> </table>	V/m	MHz	27	385	28	450	9	710	9	745	9	780	28	810	28	870	28	930	28	1720	28	1845	28	1970	28	2450	9	5240	9	5500	9
V/m	MHz																																																																	
27	385																																																																	
28	450																																																																	
9	710																																																																	
9	745																																																																	
9	780																																																																	
28	810																																																																	
28	870																																																																	
28	930																																																																	
28	1720																																																																	
28	1845																																																																	
28	1970																																																																	
28	2450																																																																	
9	5240																																																																	
9	5500																																																																	
9	5785																																																																	
V/m	MHz																																																																	
27	385																																																																	
28	450																																																																	
9	710																																																																	
9	745																																																																	
9	780																																																																	
28	810																																																																	
28	870																																																																	
28	930																																																																	
28	1720																																																																	
28	1845																																																																	
28	1970																																																																	
28	2450																																																																	
9	5240																																																																	
9	5500																																																																	
9	5785																																																																	

Info: These guidelines may not apply in all situations. Electromagnetic propagation is affected by absorption and reflection from buildings, objects and people.

The field strengths from fixed transmitters, such as wireless (cellular/cordless) telephones and mobile terrestrial radio base stations, amateur radio, AM/FM radio broadcasts and TV broadcasts cannot be accurately and theoretically predicted. In order to confirm the electromagnetic environment caused by the fixed RF transmitter, it is desirable to consider an electromagnetic field survey. If the measured field strength exceeds the compliance level as specified above at the location where the MOT-VE100 is used, the MOT-VE100 should be observed to verify correct functionality. If abnormal performance is observed, additional measures may be necessary, such as re-orienting or relocating the MOT-VE100.

App.-2 Glossary

Base

The light-blue portion of the figure below.

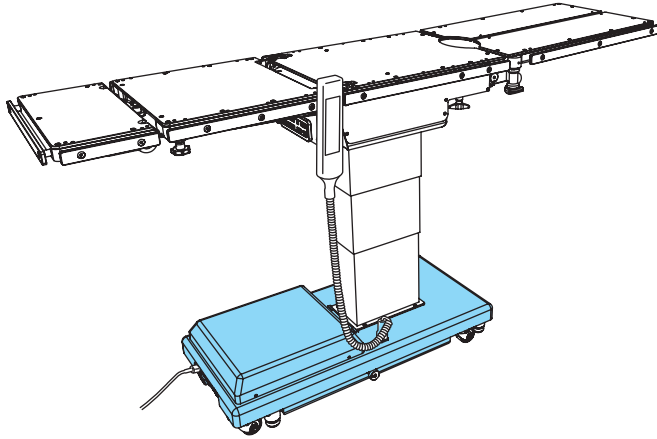

Flex/Reflex

The back section is bent upward or downward, the seat section moves to the head-up or the head-down position, and the entire tabletop moves to the “Center up” or “Center down.”

Lateral tilt

Tabletop of the operating table moves to the left-down or the right-down position.

Tabletop

The light-blue portion of the figure below.

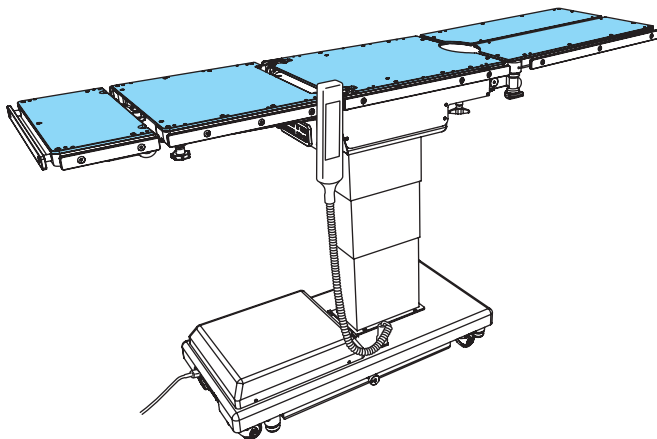

Trendelenburg

Tabletop of the operating table moves to the head-up or the head-down position.

Revision Record

2020-12-24	Ver.1	New release
2021-04-09	Ver.2	Revision
2021-11-09	Ver.3	Revision
2023-07-14	Ver.4	Revision
2024-01-25	Ver.5	Revision
2024-10-01	Ver.6	Revision



Sales Agent



EMERGO EUROPE
Westervoortsedijk 60
6827 AT Arnhem, The Netherlands



MIZUHO Corporation
3-30-13 Hongo, Bunkyo-ku
Tokyo 113-0033, Japan
<https://www.mizuho.co.jp>