

Operating Table Operator's Manual

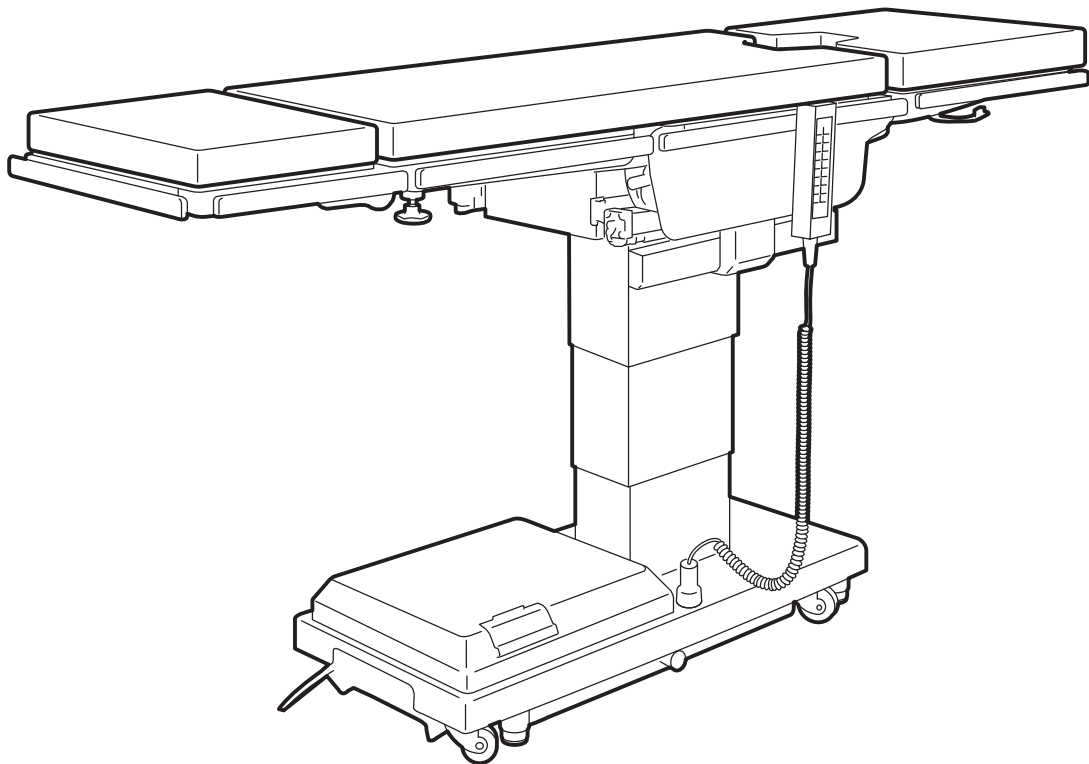

MOT-3502

TABLE OF CONTENTS

Title	Page
WARRANTY	2
Symbol mark for labeling	3
SAFETY & HEALTH SYMBOLS	4
TABLE SPECIFICATIONS	5
INSPECTIONS PERFORMED PRIOR TO PLACING UNIT INTO USE.....	8
SPECIAL USER ATTENTION.....	9
SECTION I INTRODUCTION	18
1-1. General.....	18
1-2. Power Requirements	18
1-3. Pendant Control Unit	19
1-4. Floor Lock/Brake System.....	20
SECTION II OPERATION	21
2-1. Electrical Power	21
2-2. AC Operation	21
2-3. Battery Operation	22
2-4. Automatic Shut-Off.....	22
2-5. Charging the Battery.....	23
2-6. Positioning Functions.....	24
2-7. Emergency Switch.....	30
2-8. Emergency Back-up Controls	30
2-9. Emergency Brake Release	31
2-10. Head Section	32
2-11. Leg Section Removal.....	32
2-12. Positioning	33
SECTION III MAINTENANCE.....	35
3-1. Cleaning Recommendations.....	35
3-2. Routine Inspections	36
3-3. Preventive Maintenance	37
3-4. Operator Troubleshooting	38
3-5. Maintenance Checks & Services	39
3-6. Maintenance Matrix	41
3-7. Service	43
3-8. Disposal	43
SECTION IV ELECTROMAGNETIC EMISSIONS.....	44

Although current at the time of publication, MIZUHO's policy of continuous development makes this manual subject to change without notice.

WARRANTY

MIZUHO Corporation will repair defective parts of this product without charge for one year from the date of delivery/installment except for cases of damage caused by a third party's repair, act of nature, improper use or damage on purpose. All other warranty terms and conditions are subject to regulations of MIZUHO Corporation.

EQUIPMENT LABELS

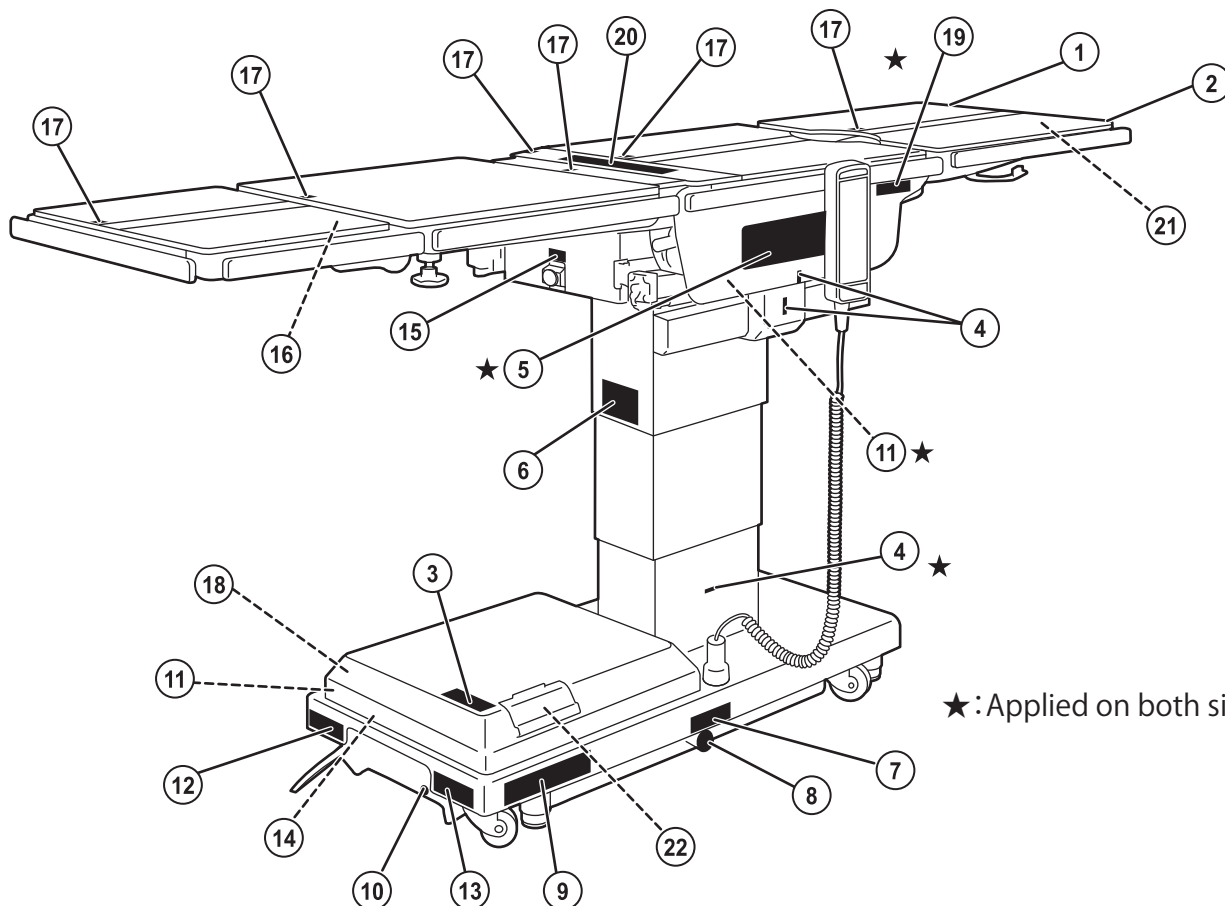

★ : Applied on both sides.

1 **C656312** □

▲ WARNING	▲ MISE EN GARDE
USE HEAD SECTION AS FOOT EXTENSION ONLY - WHEN REVERSING PATIENT ON TABLE REFER TO OPERATOR MANUAL.	UTILISER LA PARTIE AVANT UNIQUEMENT COMME RALLONGE DE PIED - CONSULTER LE MANUEL D'UTILISATION AU MOMENT DE RETOURNER LE PATIENT SUR LA TABLE.

2 **C643011** □

▲ WARNING	▲ MISE EN GARDE
DO NOT SIT ON THE LEG PLATE, OTHERWISE THE TABLE MAY FALL DOWN OR PLATE MAY COME DOWN, AND CAUSE A HURT.	NE PAS S'ASSISER SUR L'APPUI-JAMBES. DANS LE CAS CONTRAIRE, LA TABLE PEUT BASCULER OU L'APPUI-JAMBES PEUT S'ABASSER ET PROVOQUER UNE BLESSURE.

3 **C642002** □

4 **C600020** □

5 **C653530** □

6 **C653533** □

Up to 920mm(36-3/4") height 315kg MAX (700lbs)	270kg MAX (600lbs)
Over 920mm(36-3/4") height 270kg MAX (600lbs)	

7 **C653515** □

EMERGENCY BRAKE RELEASE

8 **C653516** □

9 **C656738** □

▲ DANGER	▲ DANGER
POSSIBLE EXPLOSION HAZARD IF USED IN THE PRESENCE OF FLAMMABLE ANESTHETICS.	POSSIBILITE D'EXPLOSION EN CAS D'UTILISATION EN PRESENCE D'ANESTHESIQUES INFLAMMABLES.

10 **C653513** □

11 **C653512** □

12 **C656741** □

NOTE	REMARQUE
GROUNDING RELIABILITY CAN ONLY BE ACHIEVED WHEN THE EQUIPMENT IS CONNECTED TO AN EQUIVALENT RECEPTACLE MARKED "HOSPITAL ONLY" OR "HOSPITAL GRADE".	LA FIABILITE DE MISE A LA TERRE NE PEUT ETRE OBTENUE QUE LORSQUE L'EQUIPEMENT EST CONNECTE A UNE PRISE EQUIVALENTE REPERE'E "HOPITAL UNIQUEMENT" OU "QUALITE HOPITAL".

13 **C656740** □

▲ WARNING	▲ MISE EN GARDE
TO REDUCE THE RISK OF ELECTRIC SHOCK, DO NOT REMOVE COVER OR BACK.	NE PAS RETIRER LE COUVERCLE OU LA FACE ARRIERE AFIN DE REDUIRE LE RISQUE D'ELECTROCUTION.
REFER SERVING TO QUALIFIED SERVICE PERSONNEL.	CONFIER L'ENTRETIEN AU PERSONNEL DE SERVICE QUALIFIE.
REFER TO ACCOMPANYING DOCUMENTS.	SE REFERER AUX DOCUMENTS D'ACCOMPAGNEMENT.

14 **C653529** □

REPLACE BATTERIES ONLY WITH MIZUHO REPLACEMENT PART 24V(12x2)-17Ah

15 **C653614** □

16 **C655821** □

17 **C653620** □

18 **C653623** □

19 **C653624** □

▲ WARNING	▲ MISE EN GARDE
A Patient shall be set up to more than 1cm apart from a side rail so that a patient does not touch on side rails.	Un malade sera mis loin du rail du côté plus que 1cm afin qu'unmalade ne touche pas le rail du côté.











20 **C656310** □

▲ WARNING	▲ MISE EN GARDE
POSSIBLE TABLE DAMAGE RETRACT KIDNEY LIFT COMPLETELY BEFORE RAISING BACK SECTION	DOMMAGE POSSIBLE A LA TABLE RETIRER COMPLETEMENT LE DISPOSITIF DE LEVAGE AVANT DE LEVER LA PARTIR ARRIERE

21 **C655822** □

22 **C653611** □

Symbol mark for labeling

Symbol	Description	Used On Product	Used In Manual
NOTE	Indicates important facts or helpful hints	<input type="radio"/>	<input type="radio"/>
 ISO 7010-W001	General warning sign (WARNING, CAUTION)	<input type="radio"/>	<input type="radio"/>
 IEC 60417-5840	Type B applied part	<input type="radio"/>	
IPX4 IEC 60529	Enclosure class (Splash-proof)	<input type="radio"/>	
 WEEE	Indicates waste disposal information	<input type="radio"/>	
 Blue ISO 7010-M002	Refer to instruction manual	<input type="radio"/>	
 IEC 60417-5032	Alternating current	<input type="radio"/>	
 ISO 15223-1-5.1.1	Manufacturer	<input type="radio"/>	<input type="radio"/>
 ISO 15223-1-5.1.2	European authorized representative	<input type="radio"/>	<input type="radio"/>
 ISO 15223-1-5.1.6	Catalogue number	<input type="radio"/>	
 ISO 15223-1-5.1.7	Serial number	<input type="radio"/>	
 IEC 60417-5021	Equipotentiality	<input type="radio"/>	

Symbol mark for labeling







Symbol	Description	Used On Product	Used In Manual
 <p>Red ISO 7010-P001</p>	General prohibition sign	<input type="radio"/>	
 <p>Blue ISO 7010-M001</p>	General mandatory action sign	<input type="radio"/>	
 <p>IEC 60417-5638</p>	Emergency stop	<input type="radio"/>	
 <p>IEC 60417-5019</p>	Protective earth (ground)	<input type="radio"/>	
 <p>IEC 60417-5841</p>	Defibrillation-proof Type B applied part	<input type="radio"/>	
	Medical Device	<input type="radio"/>	

TABLE SPECIFICATIONS



Maximum Lifting Capacity:

- 315kg: Up to 920 mm height
- 270kg: Over 920 mm height

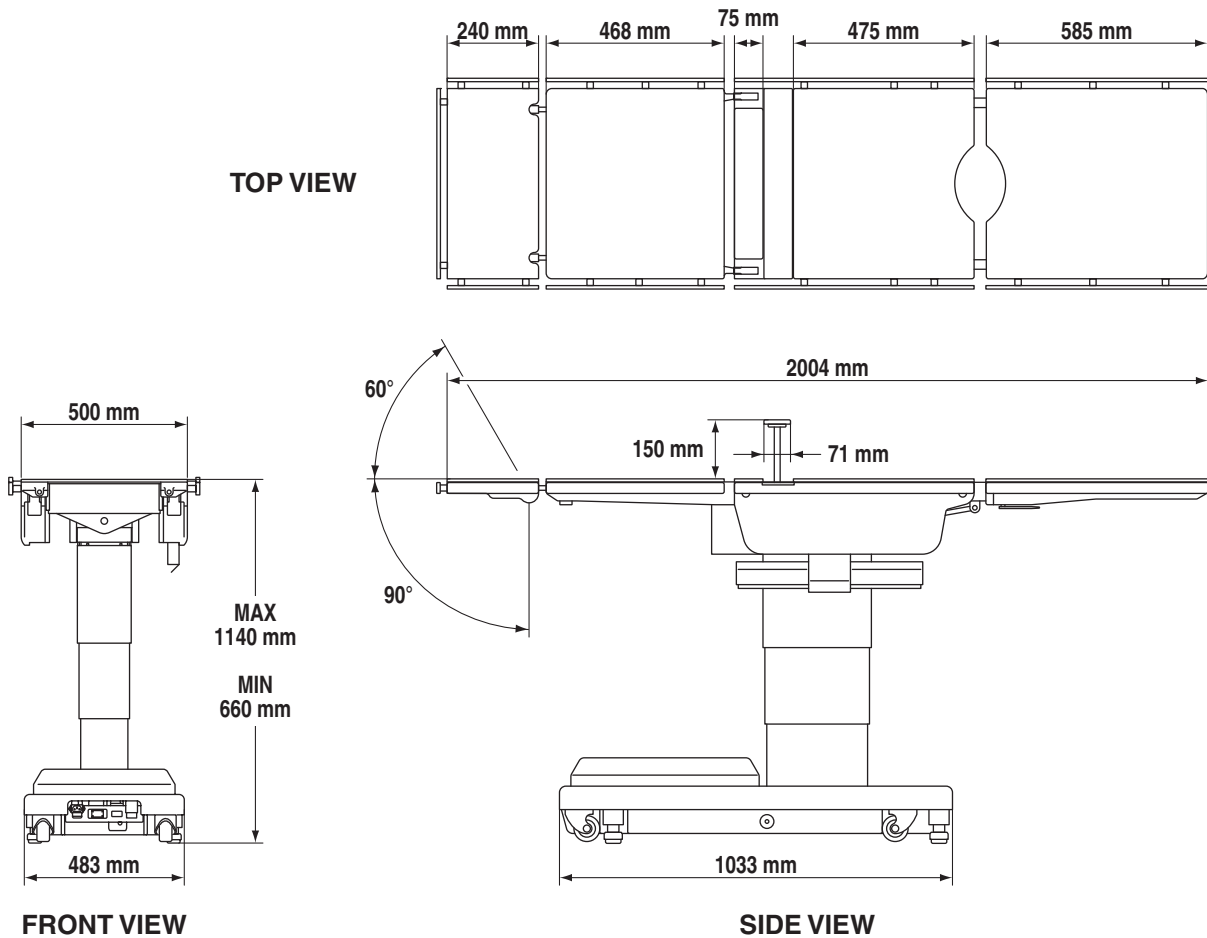
Unit Weight: 376kg

Maximum Patient Weight: 315kg

Maximum Articulating Capacity: 270kg

The height and width to be able to pass by: Height 10 mm/Width 80 mm (0.4m/s±0.1m/s)

Electrical Specifications

- Power Requirements: 100 - 240 VAC, 50 - 60 Hz, 400 VA
- Current Leakage: Less than 500 micro amps
- Power Cord : 4.5 m w/hospital grade connector (removable)
- Duty Cycle: 3 min on, 7 min off
- Battery Power: 24VDC (12Vx2) <model: FML12170-12V17Ah/Furukawa Battery>

Classification

- Class I Equipment
- Applied Parts: Table Top/Type B Applied Parts Mattress/Defibrillation Proof, Type B Applied Parts
- IPX4 Rated
- Equipment not suitable for use in the presence of flammable anesthetic mixture with AIR, OXYGEN or NITROUS OXIDE.
- This product does not intend to sterilize.

TABLE SPECIFICATIONS

Environmental Condition

	Condition of Use	Condition of Transport and Storage
Ambient Temperature	10 - 40°C	-10 - 50°C
Relative Humidity	30 - 75%	10 - 85% (No Condensation)
Atmospheric Pressure	700 - 1060 hPa	700 - 1060 hPa

Operating altitude : 2000 m max above sea level

After long period of storage - these items should be checked:

INSPECTIONS PERFORMED PRIOR TO PLACING UNIT INTO USE

Description:	Completed
1. Mains Power Function - ON/OFF Operation and LED battery function	<input type="checkbox"/>
2. Battery Power Function / Mode	<input type="checkbox"/>
3. Hand Control Operation & Back Light	<input type="checkbox"/>
4. Table Caster movement & condition	<input type="checkbox"/>
5. Operational movement of each function with load to full stroke	<input type="checkbox"/>
6. Condition of hydraulic floor lock brake cylinders & pads	<input type="checkbox"/>
7. Stability of table top	<input type="checkbox"/>
8. Stability while table floor lock brakes are activated	<input type="checkbox"/>
9. No hydraulic oil leaks	<input type="checkbox"/>
10. Hydraulic oil level	<input type="checkbox"/>
11. Table top is horizontal level when using level function	<input type="checkbox"/>
12. Operation of locking levers & locking knobs on back, leg & head sections	<input type="checkbox"/>
13. Overall appearance and cleanliness	<input type="checkbox"/>

SPECIAL USER ATTENTION

Prior to use, all personnel that may operate this table must be instructed in the correct operational procedures. This table is designed for use by trained and qualified personnel for human medical purposes only.

Initial use should not begin until after the users have been instructed by the manufacturer's representative.

A routine instructional program must be implemented by the facility for proper usage instructions for all personnel that may operate this table. The maximum lifting capacity of the MOT-3502 table is 315kg and the maximum articulation weight capacity is 270kg.

When lifting or articulating large patients, pay close attention to the patient position as well as the positioning guidelines and limitations listed in the operation instructions.

This equipment is to be used by health care professionals, including but not limited to surgeons, nurses and biomedical technicians.

This equipment may cause radio interference or may disrupt the operation of nearby equipment. It may be necessary to take mitigation measures, such as re-orienting or relocating the table or shielding the location.

The extreme positioning capabilities of the MOT-3502 Table requires special attention for possible interference points when using multiple function positioning. As with the operation of any surgical table, a certain amount of care should be exercised to position the patient safely. Although the thick pads and sheets substantially protect the patient, pinch points, located at the joints of the top section should always be considered. **BE SURE THAT THE ARMS, HANDS AND FINGERS OF THE PATIENT AND THOSE OF THE OPERATING ROOM PERSONNEL ARE CLEAR OF ALL MOVING PARTS BEFORE MOVING THE TABLE.** Refer to Pinch/Crush Point Diagram. Proper restraints should always be used for patient safety.

In case of use with other devices near the table, verify that such devices comply with electromagnetic compatibility medical standards.

Table must always be equipped and operated with (2) 12V lead acid sealed batteries available only through MIZUHO.



Remove possible obstacles before lowering or tilting the operating table.



Do not place objects on the base of the table, a danger of damage exists during positioning.

Certain accessories such as the Uro-Drain Tray, Armboards and X-Ray top can be damaged when changing the position of the table top sections. Always look first to see if a desired movement is going to interfere with any accessories in use.

The operator has the ultimate responsibility of preventing damage to the table and surrounding equipment or possible injury to the patient or staff.

The operator must ensure proper positioning is maintained to prevent compromising respiration, nerve pathways or circulation.

In general, common sense will dictate when there is a potential hazard.

SPECIAL USER ATTENTION



Possible Pinch / Crush Points

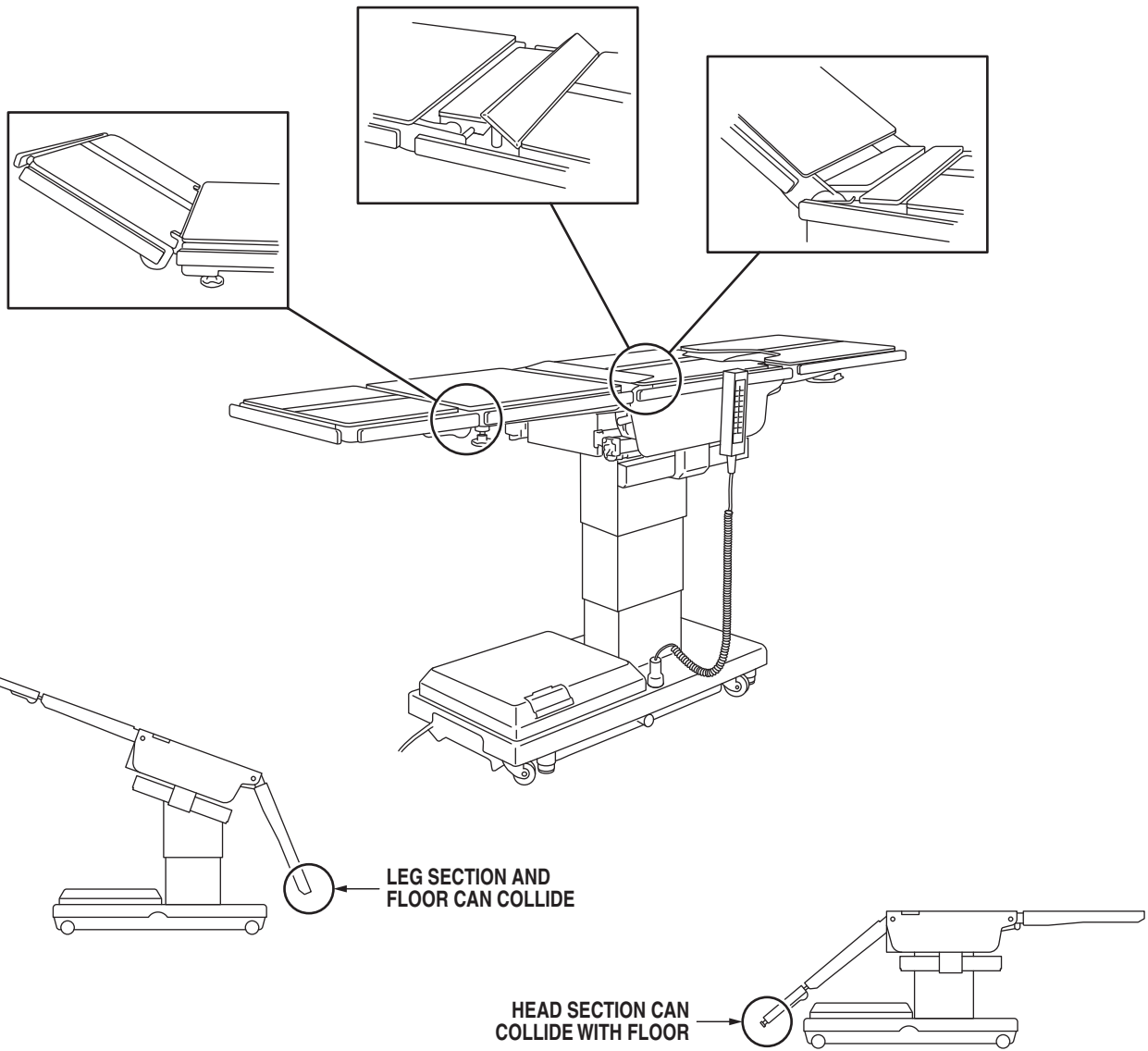

SPECIAL USER ATTENTION

Throughout this manual there are **WARNING**, **CAUTION** and **NOTE** headings. The following is a review of the precautions contained within the manual and should be reviewed by all personnel prior to operating the table.



CAUTION

Comply with the following transportation instructions when moving the MIZUHO 3502 Surgical Table.

1. Remove the power cord.
2. Place the power switch in the OFF position.
3. Tighten all handles and knobs.



CAUTION

Comply with the following packaging instructions when shipping the MIZUHO 3502 Surgical Table.

1. The MIZUHO 3502 Surgical Table shall be shipped in a suitable container, sealed from the outside atmosphere.
2. The shipping container shall employ appropriate reinforcement to prevent table vibration or movement during shipment.
3. Ensure the table brakes are locked during shipment.



CAUTION

Contact an authorized MIZUHO representative for disposal instructions for the MIZUHO Surgical Table that are in accordance with current environmental regulations for medical products.

NOTE

- Grounding reliability can only be achieved when the equipment is connected to a properly grounded receptacle. Where the integrity of the external Protective Earth Ground is compromised equipment must be operated on battery mode.
- Use only MIZUHO Replacement Parts for power cord and pendant control. Refer to Replacement Parts Section.

NOTE

If any of the buttons on the control unit are pressed continuously for longer than 4 minutes, the thermal protector of the solenoid valve will actuate and the operation will be stopped. The thermal protector will reset in approximately 30 minutes.

NOTE

The operating table a built-in self-diagnosis function to check if the operating table and control unit work properly.

1. Connect the power cord.
2. Press the BATTERY ON/OFF button on the pendant control.
3. Press the ENERGIZE button and then one of the function buttons on the pendant control. If two green battery indicators are lit, the pendant control works properly.

NOTE

Activating any function button will activate the brake system. Using the TABLE UP function to set the brakes provides a visual assurance that the brakes are locked without altering the table position, except when emergency brake is released.

SPECIAL USER ATTENTION



WARNING

Possible explosion hazard exists if table is used in the presence of FLAMMABLE ANESTHETICS.

NOTE

An equalization terminal is located under the main power panel. This is provided as an alternate pathway to reduce the risk of static shock hazards. Always follow recommended grounding procedures to ensure patient and staff safety.



WARNING

To avoid the risk of electric shock, this equipment must only be connected to a supply main with Protective earth. Power Cord has to be used the one which has a logotype of MIZUHO.



WARNING

Please don't position the surgical table in such way that the operator has difficulty to disconnect the Equipment by plug or appliance outlet.

NOTE

Prior to all surgical procedures, make sure the battery charge is sufficient for anticipated duration and use.

NOTE

The table will operate correctly on battery power with the power cord connected to a wall outlet or disconnected.

NOTE

Battery Operation must be turned OFF at the pendant control. It cannot be turned OFF using the main power switch.

NOTE

Turning the base Main Power Switch ON will change the table operation to AC power.

NOTE

When the red Battery Power Indicator light starts to blink (indicating low power in battery) the table will operate for approximately 5 continuous minutes, typically long enough to use the table for the rest of the day.

NOTE

The charging system operates ONLY when the table is in AC operation mode. While charging a battery, the operation of Power on/ off can be performed with a BATT ON/OFF switch.

NOTE

The table can be operated on AC power while the battery is being recharged.



WARNING

If the table is stored for a period greater than 6 months, the batteries should be removed and stored in a dry, clean condition at a storage temperature of 68°F (20°C). Batteries should be recharged every 6 months of product storage.



WARNING

A operator of operating table has to perform his/her activity at the position which is indicated in below drawing where he/she can push the emergency stop switch immediately and observe his/her patients.



WARNING

Please confirm that the operating table is fixed stably after applying the brakes.

SPECIAL USER ATTENTION

**WARNING**

DO NOT unlock brakes when a patient is on the table. An uneven patient weight load may cause instability.

**WARNING**

If circumstances demand table brakes to be unlocked, the patient must be centered and evenly distributed on the table top (i.e. supine or prone position) with the table lowered to its lowest height position. The maximum patient weight should not exceed 230kg. Table top slide must be centered (indicated by a red LED light on the pendant control) prior to unlocking brakes. Patient's head must be on the head section. Head section must be attached in its normal orientation to the table's back section.

**WARNING**

- Prior to unlocking brakes, check for obstructions on the floor that might prevent the table from moving smoothly to new location. Re-lock the brakes immediately once the final position is reached and before commencing surgery. To move the table safely one staff member should be positioned at the head end and one at the foot end. If the patient weight exceeds 115kg, four staff members are required to move the table and ensure patient safety. Table brakes should remain locked at all times if patient weight exceeds 230kg.
- Don't move a table with patient carried. There is a risk that patient may fall and injure or staff may injure.
- Don't move a table with heavy object carried. There is a risk that heavy object may fall and damage or staff may injure.

NOTE

With an evenly distributed patient weight load, all table positioning functions will operate smoothly and quietly with a patient weight of up to 270kg.

**WARNING**

To maximize patient safety, utilize proper restraint methods during extreme Trendelenburg positioning.

**WARNING**

To maximize patient safety, utilize proper restraint methods during extreme lateral tilt positioning.

NOTE

If the table top is slid toward the foot end, the back section will not go below horizontal. An audible alarm will sound.

NOTE

To prevent damage to the kidney lift, a safety interlock prevents the back section from going more than 45° above horizontal if the kidney lift is not all the way down. An audible alarm will sound.

NOTE

- Maximum Lifting Capacity is 315kg up to 920mm height, and 270kg from 920mm to 1140mm height.
- 920mm height is the position which can be confirmed the line of the Elevation Cover while elevating.

**CAUTION**

Don't apply the load exceeding 270 kg at over 920mm height. This might cause malfunction.

SPECIAL USER ATTENTION

NOTE

If the leg section is positioned more than 45° below horizontal, the top will not slide toward the head end. An audible alarm will sound.

NOTE

If the back section is positioned below horizontal, the top will not slide toward the foot end. An audible alarm will sound.

**CAUTION**

The Leg section may hit the table base or the floor if both the leg and elevation systems are placed in their full down position.

NOTE

If the top is slid toward the head end the leg section will only go down 45°. An audible alarm will sound.

NOTE

When FLEX button is activated and if the top is slid toward the foot end, the back section will not go below horizontal. An audible alarm will sound.

NOTE

Return to Level will lower the kidney lift.

NOTE

To prevent damage to the kidney lift, a safety interlock prevents the kidney lift from going up if the back section is 45° above horizontal. An audible alarm will sound.

NOTE

Elevation, slide and brake system functions are not affected by the return to level function.

**CAUTION**

Please use the emergency switch at the urgent case only.

**CAUTION**

The safety interlock system is not operational when the emergency back-up control switches are used.

**CAUTION**

The EMERGENCY BRAKE LOCK switch does not activate the brake system timer. The switch must be held until the brakes are completely locked, approximately 10 seconds.

NOTE

The emergency back-up control switches will function when the table is operating on AC power, battery power, or turned off.

NOTE

- The Emergency Brake Release Valve must be closed and tightened (counter-clockwise) before activating any hydraulic function.
- If the Emergency Brake Release Valve has been operated, the BRAKE UNLOCK button on the pendant control will have to be pressed to reset the timer circuit before brakes will lock again.

NOTE

The leg section with the x-ray top + pad attached weighs 14kg. It is recommended that the x-ray top and pad be removed before detaching the leg section.

SPECIAL USER ATTENTION



Ensure that the Leg section is properly engaged and secured to pins before use to prevent injury.



Consult manufacturer's instructions when using high frequency surgical equipment, cardiac defibrillator and cardiac defibrillator monitors. Improper operation procedures might cause a burn on an operators or patient, and also cause the malfunction of the product.



- When a patient is put on a mattress and his/her position is set up, a patient shall be set up to more than 1 cm apart from a side rail so that a patient dose not touch on side rails (metal).
- The mattress should be attached in order not to come off while being in use.



When an antistatic pathway is required, the table has to be used on an antistatic floor.



The antistatic properties of the table are dependent on the use of the original pad set which was furnished with the table or an alternate approved replacement.



Certain accessories may limit weight capacities. Check with your MIZUHO representative.



MIZUHO Products are guaranteed for proper performance with the use of genuine MIZUHO accessories.

Accessories and products not furnished by MIZUHO have not been tested for proper performance and safety. Such applications or use are at the discretion of the user to ensure patient and staff safety.



- MIZUHO surgical tables are designed to be used by trained healthcare professionals only.
- Place a patient on the table after a 70mm minimum thickness mattress is certainly attached onto the table top for safeness of a patient.
- Attach a mattress onto the table properly in order not to slip off or come off the table during operation.
- Install a table board in order not to recognize the fixing screws.
- Put a patient on the table after the mattress is changed to proper position when the mattress is found to be out of proper position.



Do not use worn or damaged accessories, they represent an injury hazard.



Set up a patient's position in order not to touch the metal parts like table board or side rail of table top directly. Metal part might cause a burn.

SPECIAL USER ATTENTION

NOTE

- A mattress is an applied part.
- Usable mattresses are as following.

50005M2
360L6M2
360L8M2

Mattress's shape is suitable for each table board.

- Tag which indicates that a mattress is an applied part and is made by MIZUHO is attached on a mattress.

 **WARNING** 

Personal injury to patient or staff may result from a lack of proper maintenance of this equipment.

 **CAUTION** 

Caution should be taken when cleaning the table to prevent excessive fluid entry into electrical connectors.

 **WARNING** 

Always follow the national blood-borne pathogens standards for protective clothing, including gloves, masks and eye protection when cleaning the surgical table.

 **CAUTION** 

Thoroughly read and follow the manufacturer's directions for all cleaning fluids. DO NOT use cleaners containing phenolics. Avoid use of oxidizing products with Chloric derivatives such as bleach or Peracetic Acid.

 **CAUTION** 

When using spray cleaners DO NOT spray fluids directly into electrical receptacles or micro switches.

 **CAUTION** 

Before replacing pads on the table, make sure the pads and all mating surfaces are completely dry. Moisture trapped between the pads and mating surfaces may cause distortion of table tops.

 **WARNING** 

- DO NOT disassemble the table. Unauthorized disassembling may cause electric shock or malfunction.
- Please contact your local distributor or manufacturer for maintenance or repair. The operating table should only be serviced or maintained by a factory trained personnel.

NOTE

Technical description of this product is due to the Maintenance Manual. The contents of Maintenance Manual are as follows.

SECTION I	HYDRAULIC SYSTEM
SECTION II	MECHANICAL TABLE ADJUSTMENTS
SECTION III	HYDRAULIC TROUBLESHOOTING
SECTION IV	ELECTRICAL SYSTEM
SECTION V	ELECTRICAL TROUBLESHOOTING

Maintenance Manual can be obtained only by the person who has had the service training of MIZUHO.

 **CAUTION** 

Do not use the table if any of the inspection points fail.

SPECIAL USER ATTENTION

Always inspect product prior to use to ensure safe and correct operation. Any product deemed to be malfunctioning should be removed from service immediately and labeled inoperable. Refer all service to a MIZUHO authorized service representative.

NOTE

The elevation cylinder should be completely down, the brakes released and all the other control functions in their neutral position when checking hydraulic oil level.

NOTE

Any serious incident that has occurred in relation to the device should be reported to the manufacturer and the competent authority in which the user and / or patient is established.

SECTION I INTRODUCTION

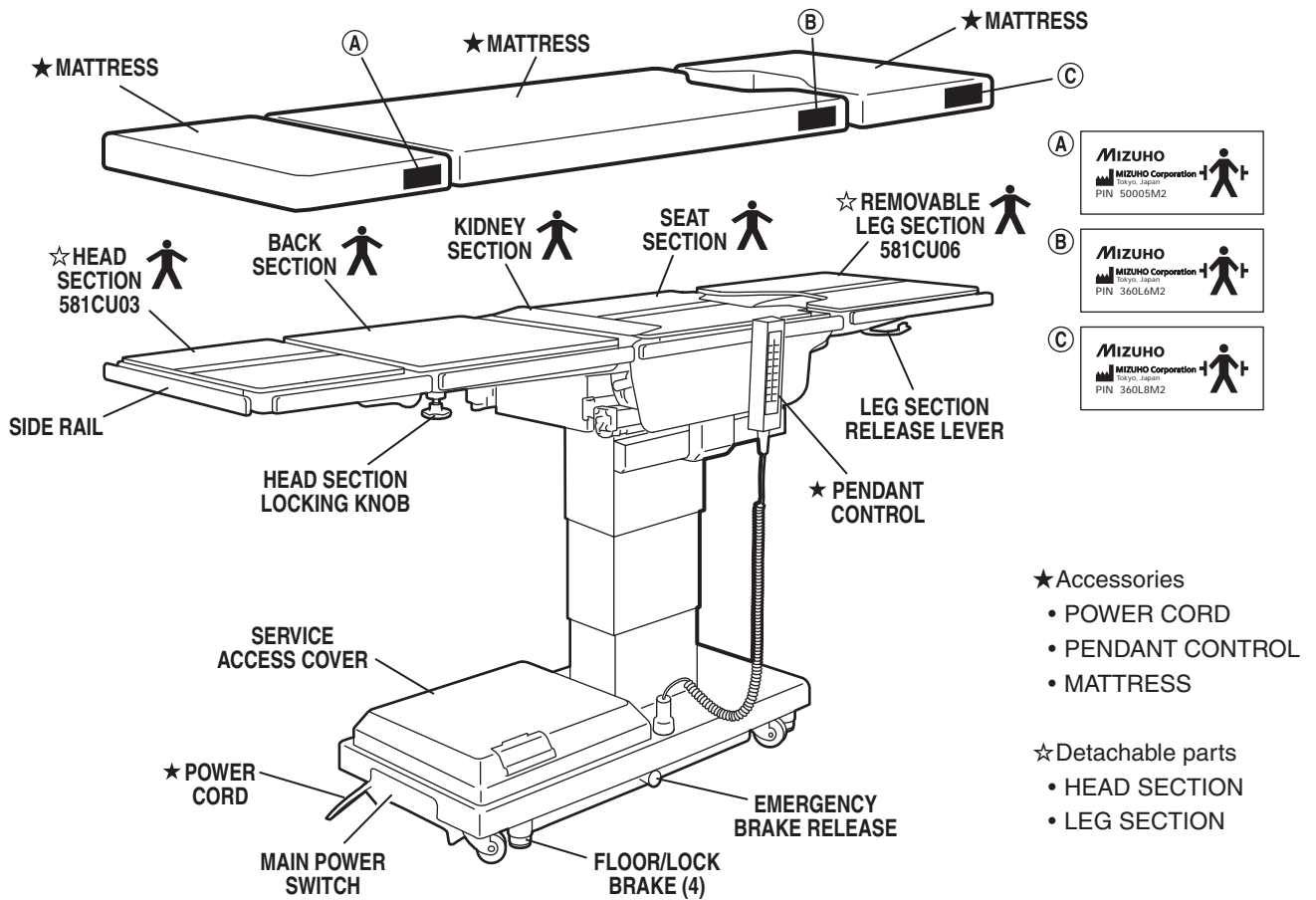

Figure 1-1. MOT-3502

1-1. General

- a. **Intend Use.** This Product is intended for holding a patient on the surgical operation.
- b. A place to use this product should be an operating room in the hospital.
- c. The user of this product should be doctors or nurses or medical engineers who have sufficient knowledge of this product.

MIZUHO's MOT-3502 Surgical Table is an electro-hydraulically operated, general purpose surgical table. See figure 1-1.

The electro-hydraulic positioning functions operated by the hand-held, push button, pendant control unit are: Trendelenburg, lateral tilt, back section, elevation, leg section, top slide, flex/reflex, kidney lift, return to level and the floor lock/brake system.

Manual controls are provided for head section positioning, emergency brake release and leg section removal.

1-2. Power Requirements

The MOT-3502 Surgical Table requires a 100-240VAC, 50-60Hz electrical power supply. The table is equipped with a removable 4.5m long power cord. The main power ON/OFF switch is located on the electrical panel on the front edge of the table base. See figure 1-2.

The battery charging indicator and an area for an optional foot control connector are also located on the electrical panel.

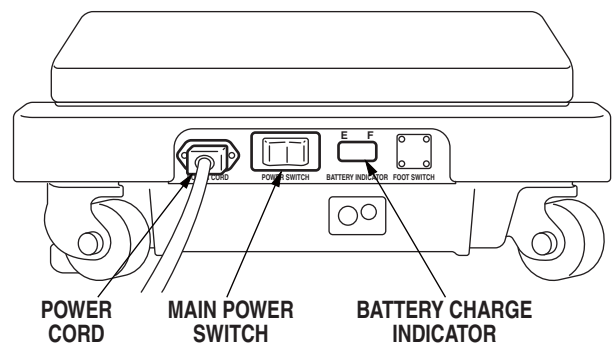

Figure 1-2. Electrical Panel

SECTION I INTRODUCTION

NOTE

- Grounding reliability can only be achieved when the equipment is connected to a properly grounded receptacle. Where the integrity of the external Protective Earth Ground is compromised equipment must be operated on battery mode.
- Use only MIZUHO Replacement Parts for power cord and pendant control. Refer to Replacement Parts Section.

NOTE

If any of the buttons on the control unit are pressed continuously for longer than 4 minutes, the thermal protector of the solenoid valve will actuate and the operation will be stopped. The thermal protector will reset in approximately 30 minutes.

NOTE

The operating table a built-in self-diagnosis function to check if the operating table and control unit work properly.

1-3. Pendant Control Unit

The hand-held pendant control unit (figure 1-3) has a non-slip rubber cover which assures a positive grip during use. A spring clip hanger is located on the back of the control for storage. When the Pendant Control is not in use, it should be stored on a convenient side or end rail.

1. Connect the power cord.
2. Press the BATTERY ON/OFF button on the pendant control.
3. Press the ENERGIZE button and then one of the function buttons on the pendant control. If two green battery indicators are lit, the pendant control works properly.

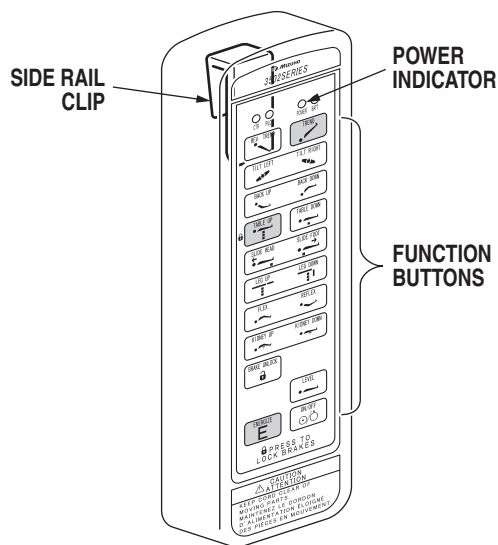

Figure 1-3. Pendant Control Unit

The function push buttons are identified with internationally recognized symbols and abbreviated descriptions for all functions. See figure 1-4. When illuminated the Trendelenburg and table up buttons are red, the remaining buttons are all green.

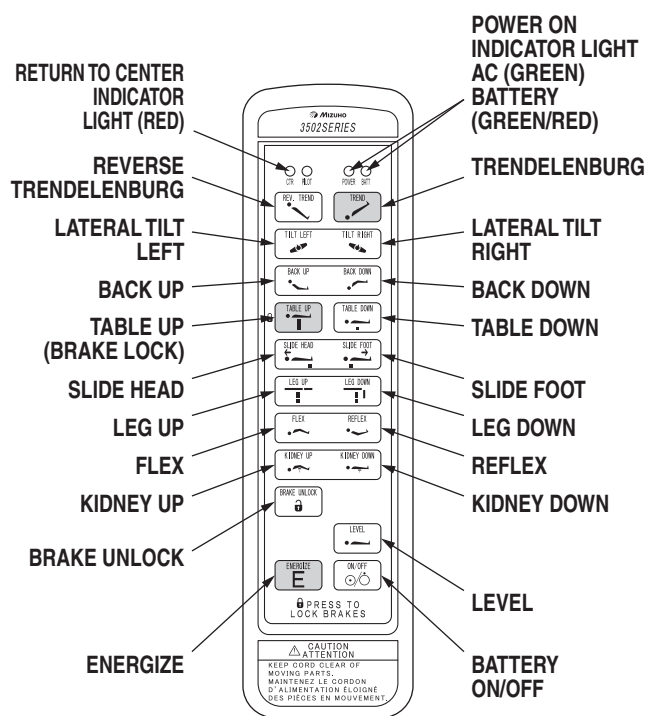

Figure 1-4. Function Buttons

1-4. Floor Lock/Brake System

The floor lock/brake system consists of four self-leveling, hydraulic brake cylinders which raise and support the table base off from the casters. Press the TABLE UP button on the pendant control to set the table's brakes. An electronic timer will activate the brake system until the brakes are completely set, approximately 8-10 seconds.

NOTE

Activating any function button will activate the brake system. Using the TABLE UP function to set the brakes provides a visual assurance that the brakes are locked without altering the table position, except when emergency brake is released.

SECTION II OPERATION

2-1. Electrical Power

The 3502 table will operate on either AC or battery power.



WARNING

Prior to operating the table, observe all table caution labels and review the SPECIAL USER ATTENTION section in the front of this manual.



WARNING

Possible explosion hazard exists if table is used in the presence of FLAMMABLE ANESTHETICS.

NOTE

An equalization terminal is located under the main power panel. This is provided as an alternate pathway to reduce the risk of static shock hazards. Always follow recommended grounding procedures to ensure patient and staff safety.

2-2. AC Operation

Use the following procedures to operate the table on AC power.

a. Make sure the Power cord is securely attached to the table. To install the power cord, align the cord connector with the base connector, insert the cord into the connector until it locks in place. See figure 2-1. Plug the cord into a properly grounded, Hospital Grade, AC outlet. Make sure the power cord is routed to the outlet to prevent it from being in the way of operating personnel. To remove the power cord, and pull the cord connector out of the base connector.



WARNING

To avoid the risk of electric shock, this equipment must only be connected to a supply main with Protective earth. Power Cord has to be used the one which has a logotype of MIZUHO.

b. Activate the POWER SWITCH located on the electrical panel. The switch will illuminate.

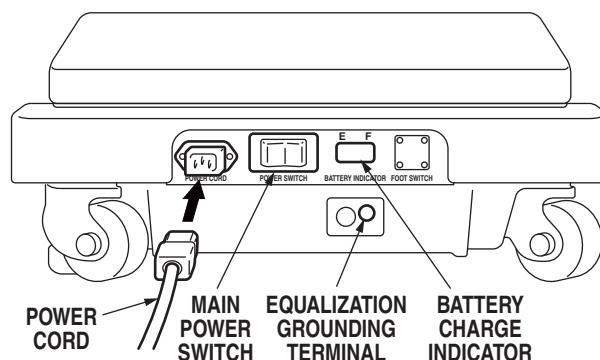

Figure 2-1. Electrical Panel

The pendant control buttons and the green AC, POWER indicator light located in the upper right corner of the pendant control will illuminate. See figure 2-2.

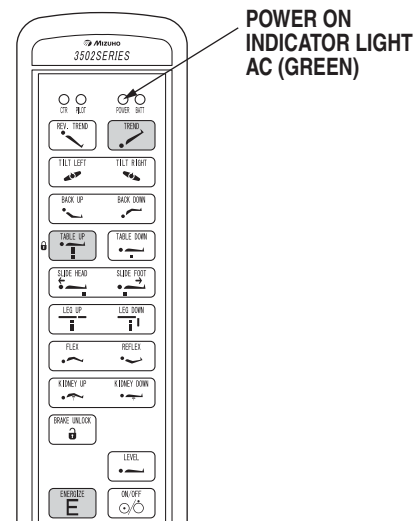

Figure 2-2. Pendant Control

c. The table is now ready for AC operation.

d. When operating table is disconnected from commercial power supply, a power supply cable has to be pulled out from AC outlet.



WARNING

Please don't position the surgical table in such way that the operator has difficulty to disconnect the Equipment by plug or appliance outlet.

SECTION II OPERATION

2-3. Battery Operation

a. Make sure the Main Power Switch indicator light, on the electrical panel, is OFF. See figure 2-1. If the indicator light is ON, turn AC operation OFF with the main power switch.

NOTE

Prior to all surgical procedures, make sure the battery charge is sufficient for anticipated duration and use.

NOTE

The table will operate correctly on battery power with the power cord connected to a wall outlet or disconnected.

b. Press the BATT ON/OFF button on the hand-held pendant control. The pendant control buttons, the red BATTERY indicator light, located in the upper right corner of the pendant control and the Battery Charge Indicator on the electrical panel will illuminate. See figure 2-3.

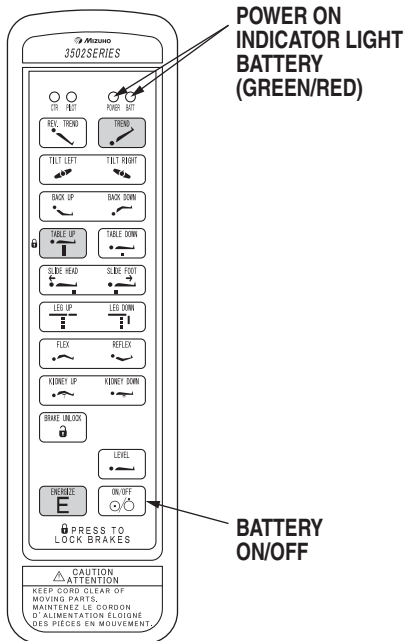

Figure 2-3.

c. The table is now ready for BATTERY operation.

d. To extend the battery charge life, turn the BATTERY power OFF with the pendant control when the table is not going to be used.

NOTE

Battery Operation must be turned OFF at the pendant control. It cannot be turned OFF using the main power switch.

2-4. Automatic Shut-Off

a. To prevent unnecessary discharge of the battery, a timer is built into the battery circuit. This timer will automatically shut the battery power OFF after 2 hours of table inactivity.

b. To turn the table ON again, press the BATT ON/OFF button on the pendant control, the pendant control buttons and the red indicator light will illuminate.

NOTE

Turning the base Main Power Switch ON will change the table operation to AC power.

SECTION II OPERATION

2-5. Charging the Battery

Batteries should be charged:

- When the table is placed into initial service
- As indicated by Battery Charge Indicator
- Every week under normal service conditions
- Prior to all Surgical Procedures

a. Battery Indicator

In battery mode, three green LEDs and four yellow LEDs and three red LEDs are turned on sequentially according to a charge state. And in charging mode, three green LEDs and four yellow LEDs and one red LED turned on sequentially and turned off, then turned on sequentially again. The following list shows the battery charge level as indicated by the lighted bars.

Battery mode

4yellow·3green	100% (Fully charged)
4yellow·2green	89% (Charged)
4yellow·1green	78% (Charged)
4yellow	67% (Charged)
3yellow	56% (Charged)
2yellow	45% (Needs-Charging: BATT indicator on pendant will flash)
1yellow	34% (Needs-Charging: BATT indicator on pendant will flash)
3red	23% (Needs-Charging: BATT indicator on pendant will flash)
2red	12% (Needs-Charging: BATT indicator on pendant will flash)
1red	1% (Needs-Charging: inoperable)

Charging mode

1yellow	34% (Charging)
2yellow	45% (Charging)
3yellow	56% (Charging)
4yellow	67% (Charging)
4yellow·1green	78% (Charging)
4yellow·2green	89% (Charging)
4yellow·3green	100% (Fully charged)
1red	Battery Fuse Blown (inoperable)

Error mode

2red	Battery Fuse Blown (Need-Replace fuses)
------	-----------------------------------------

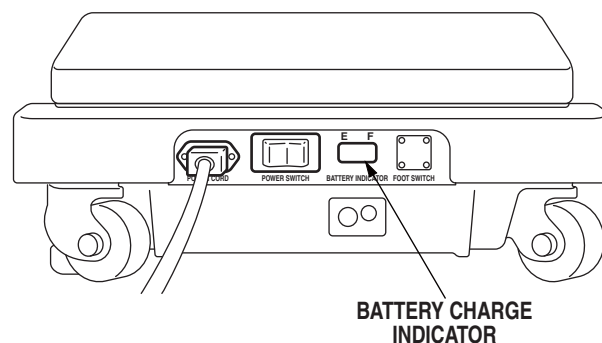

Figure 2-4. Battery Charge Indicator

- b. If the battery needs to be charged when operating the table on battery power, the red Battery Power indicator light on the pendant control will begin to blink.

NOTE

When the red Battery Power Indicator light starts to blink (indicating low power in battery) the table will operate for approximately 5 continuous minutes, typically long enough to use the table for the rest of the day.

NOTE

The charging system operates ONLY when the table is in AC operation mode. While charging a battery, the operation of Power on/ off can be performed with a BATT ON/OFF switch.

- c. To recharge the battery, make sure the power cord is connected, plugged into a AC wall outlet and the main POWER SWITCH is ON.

NOTE

The table can be operated on AC power while the battery is being recharged.

SECTION II OPERATION

d. A full battery charge will last approximately 2 weeks under normal operating conditions. However, it is recommended to charge the batteries at the end of each week to establish a normal routine protocol. Lead acid batteries last longer if they are not permitted to fully discharge. The table features (2) 12 volt, sealed, lead acid batteries which require no manual maintenance. Lead acid gel batteries, under a proper charging program, feature an approximate normal life of 4 years.



WARNING

If the table is stored for a period greater than 6 months, the batteries should be removed and stored in a dry, clean condition at a storage temperature of 68°F (20°C). Batteries should be recharged every 6 months of product storage.

e. If the life of battery is degraded, the power might not be supplied from battery properly in the case that AC power supply can not be used due to the power failure.

2-6. Positioning Functions

The hand-held pendant control (figure 2-5) activates the following table functions:

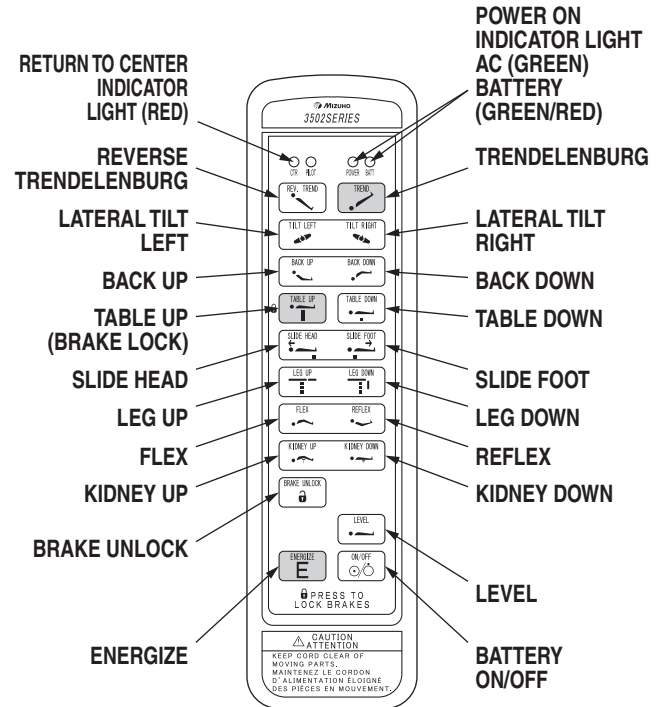

Figure 2-5. Pendant Control Function Buttons



WARNING

A operator of operating table has to perform his/her activity at the position which is indicated in below drawing where he/she can push the emergency stop switch immediately and observe his/her patients. See figure 2-6.

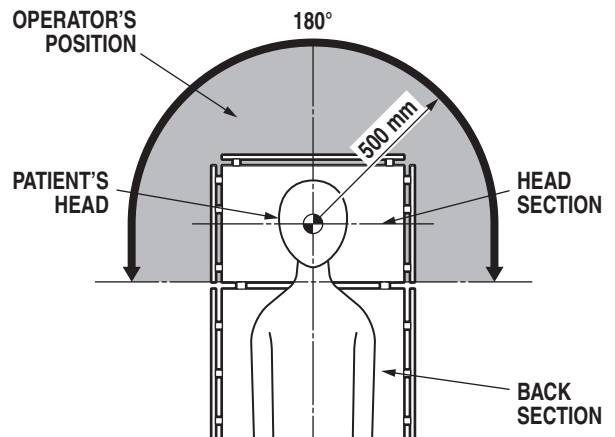

Figure 2-6. Operator's Position

SECTION II OPERATION

Each positioning is operating while pushing the function button, and positioning will stop when the button is released. When an opposite function button against the current operation is pushed, current function is canceled.

a. Floor Lock/Brake System To activate the brakes without affecting table positioning, press the ENERGIZE button and then the TABLE UP button. See figure 2-7. The elevation cylinder will not function until the brakes are completely extended.

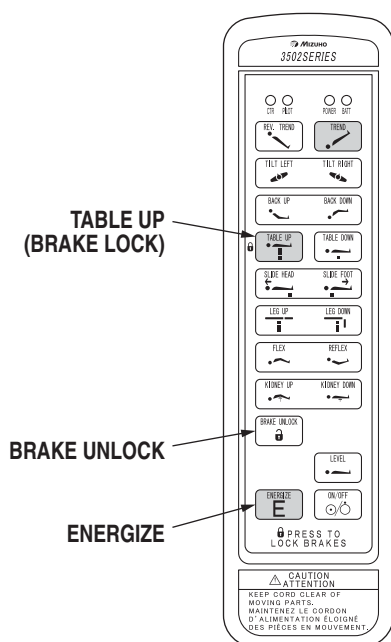

Figure 2-7. Brake System Activation

Press the ENERGIZE button and then the BRAKE UNLOCK button on the pendant control to release the four self-leveling brake feet in order to move the table. See figure 2-7. The brake delay circuit automatically retracts the brake system. It takes approximately 7-8 seconds to totally release the system.

The table will continue working until stopping when the function button for brake fixing and releasing is pushed at least once.

The following operation should be performed when making an operating table shut down.

At Battery Mode

Push the ON/OFF button of Pendant Control Box.

At AC Mode

1. Unplug the Power cord from AC outlet
2. Switch to Battery Mode.
3. Push the ON/OFF button of Pendant Control Box.

At unusual operation

Push the emergency stop switch.



WARNING

Please confirm that the operating table is fixed stably after applying the brakes.



WARNING

DO NOT unlock brakes when a patient is on the table. An uneven patient weight load may cause instability.



WARNING

If circumstances demand table brakes to be unlocked, the patient must be centered and evenly distributed on the table top (i.e. supine or prone position) with the table lowered to its lowest height position. The maximum patient weight should not exceed 230kg. Table top slide must be centered (indicated by a red LED light on the pendant control) prior to unlocking brakes. Patient's head must be on the head section. Head section must be attached in its normal orientation to the table's back section.

SECTION II OPERATION



WARNING

- Prior to unlocking brakes, check for obstructions on the floor that might prevent the table from moving smoothly to new location. Re-lock the brakes immediately once the final position is reached and before commencing surgery. To move the table safely one staff member should be positioned at the head end and one at the foot end. If the patient weight exceeds 115kg, four staff members are required to move the table and ensure patient safety. Table brakes should remain locked at all times if patient weight exceeds 230kg.

- Don't move a table with patient carried. There is a risk that patient may fall and injure or staff may injure.
- Don't move a table with heavy object carried. There is a risk that heavy object may fall and damage or staff may injure.

NOTE

With an evenly distributed patient weight load, all table positioning functions will operate smoothly and quietly with a patient weight of up to 270kg.

b. Trendelenburg To place the table in a Trendelenburg (head down) position, press the ENERGIZE button and then the TREND button (figure 2-8). Trendelenburg positioning of up to 25° may be obtained. To place the table in a reverse Trendelenburg (head up) position, press the ENERGIZE button and then the REV TREND button. Reverse Trendelenburg positioning of up to 20° may be obtained.



WARNING

To maximize patient safety, utilize proper restraint methods during extreme Trendelenburg positioning.

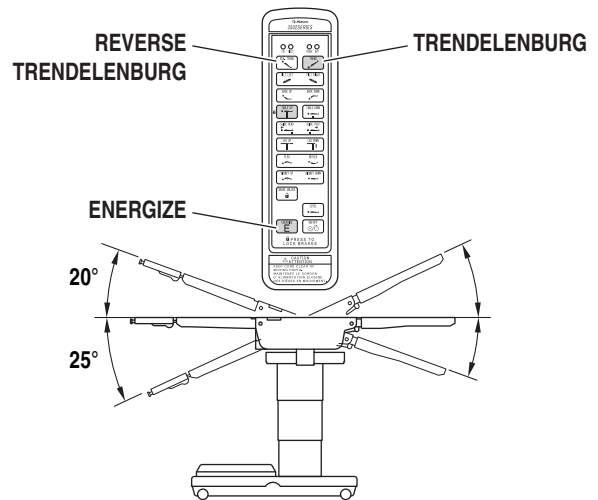

Figure 2-8. Trendelenburg Positioning

c. Lateral Tilt To achieve lateral tilt right (as viewed from the head end of the table), press the ENERGIZE button and then the TILT RIGHT button (figure 2-9). Tilt of up to 20° may be obtained. To achieve lateral tilt left, press the ENERGIZE button and then the TILT LEFT button. Tilt of up to 20° may be obtained.



WARNING

To maximize patient safety, utilize proper restraint methods during extreme lateral tilt positioning.

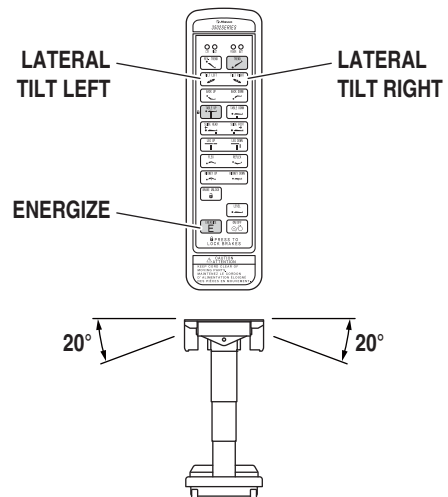

Figure 2-9. Lateral Tilt Positioning

SECTION II OPERATION

d. Back Section To raise the back section, press the ENERGIZE button and then the BACK UP button (figure 2-10). The back section will raise up to 90° above horizontal. To lower the back section, press the ENERGIZE button and then the BACK DOWN button. The back section will go down to 40° below horizontal.

NOTE

If the table top is slid toward the foot end, the back section will not go below horizontal. An audible alarm will sound.

NOTE

To prevent damage to the kidney lift, a safety interlock prevents the back section from going more than 45° above horizontal if the kidney lift is not all the way down. An audible alarm will sound.

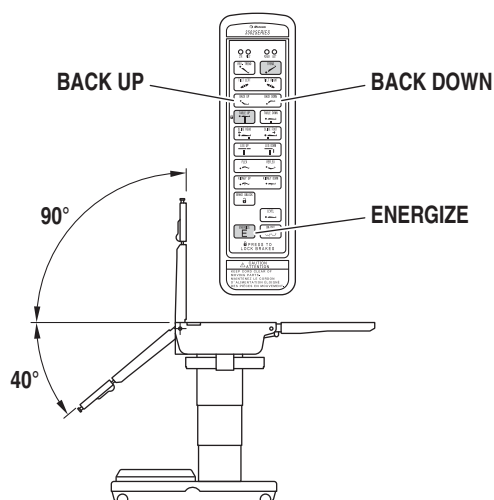

Figure 2-10. Back Section Positioning

e. Elevation To raise table top, press the ENERGIZE button and then the TABLE UP button (figure 2-11). The table will lift a patient weight of 315kg up to a maximum height of 1140mm. To lower the table top, press the ENERGIZE button and then the TABLE DOWN button. The table top will go down to a minimum height of 660mm (minus pad).

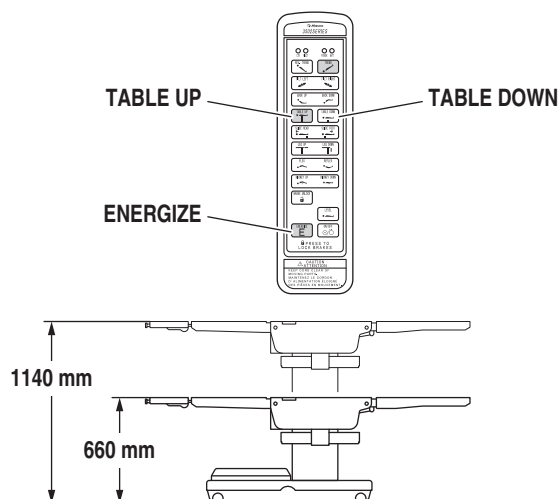

Figure 2-11. Elevation Function

NOTE

- Maximum Lifting Capacity is 315kg up to 920mm height, and 270kg from 920mm to 1140mm height.
- 920mm height is the position which can be confirmed the line of the Elevation Cover while elevating.

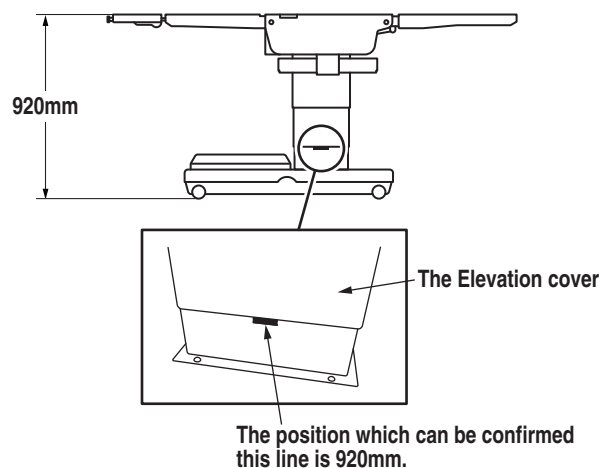

Figure 2-12. 920mm height



Don't apply the load exceeding 270 kg at over 920mm height. This might cause malfunction.

SECTION II OPERATION

f. Top Slide To move the table top toward the head end, press the ENERGIZE button and then the SLIDE HEAD button. From center position, the top will slide up to 195mm. See figure 2-13.

NOTE

If the leg section is positioned more than 45° below horizontal, the top will not slide toward the head end. An audible alarm will sound.

To move the table top toward the foot end, press the ENERGIZE button and then the SLIDE FOOT button. From center position, the top will slide up to 335mm. Slide function will stop and RETURN CTR Indicator will illuminate when table top is centered.

NOTE

If the back section is positioned below horizontal, the top will not slide toward the foot end. An audible alarm will sound.

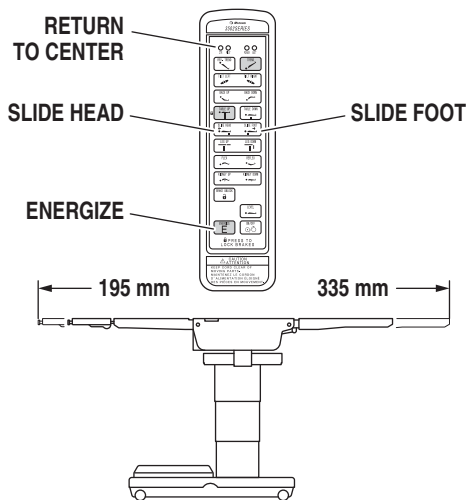

Figure 2-13. Top Slide

g. Leg Section To lower the leg section, press the ENERGIZE button and then the LEG DOWN button (figure 2-14). The leg section will go down to 100° below horizontal. To raise the leg section, press the ENERGIZE button and then the LEG UP button. The leg section will go up to level.

CAUTION

The Leg section may hit the table base or the floor if both the leg and elevation systems are placed in their full down position.

NOTE

If the top is slid toward the head end the leg section will only go down 45°. An audible alarm will sound.

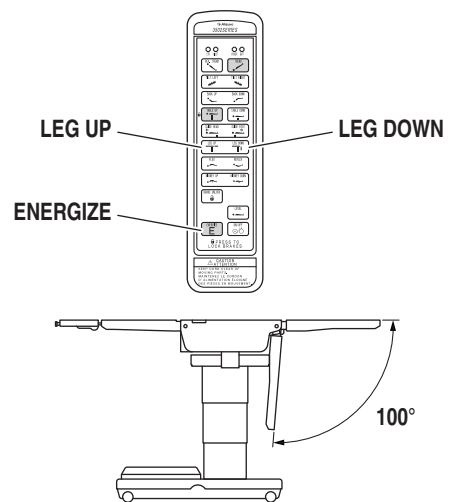

Figure 2-14. Leg Section Positioning

SECTION II OPERATION

h. Flex Positioning To place the table top in a flex position from horizontal, press the ENERGIZE button and then the FLEX button (figure 2-15). To return the table top to a horizontal position or into a reflex position, press the ENERGIZE button and then the REFLEX button.

NOTE

When FLEX button is activated and if the top is slid toward the foot end, the back section will not go below horizontal. An audible alarm will sound.

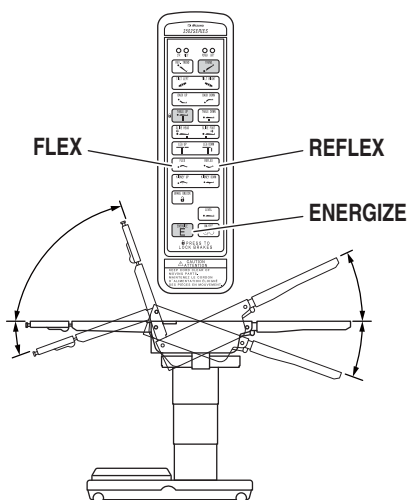

Figure 2-15. Flex/Reflex Positioning

i. Kidney Lift To raise the built-in kidney lift, press the ENERGIZE button and then the KIDNEY UP button (figure 2-16). Up to 150mm of lift can be achieved. Press the ENERGIZE button and then the KIDNEY DOWN button to lower the kidney lift.

NOTE

Return to Level will lower the kidney lift.

NOTE

To prevent damage to the kidney lift, a safety interlock prevents the kidney lift from going up if the back section is 45° above horizontal. An audible alarm will sound.

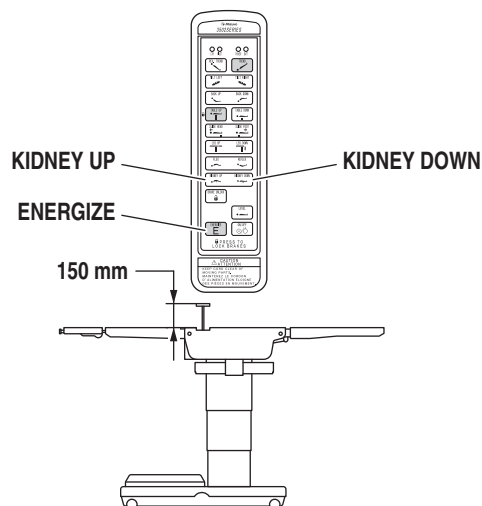

Figure 2-16. Kidney Lift Positioning

j. Return To Level To return the table top to a level position, press the ENERGIZE button and then the LEVEL button (figure 2-17).

NOTE

Elevation, slide and brake system functions are not affected by the return to level function.

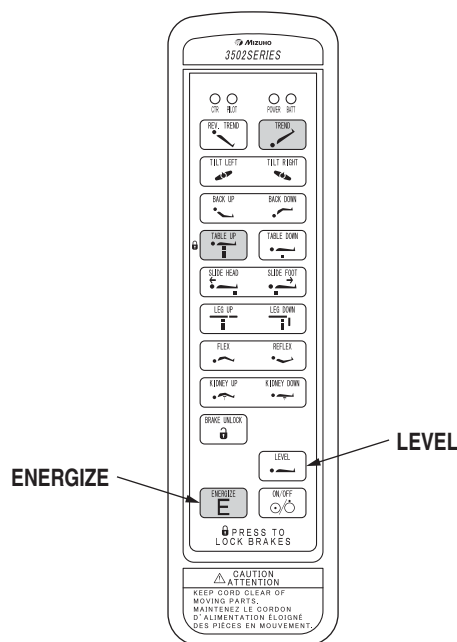

Figure 2-17. Return to Level

SECTION II OPERATION

2-7. Emergency Switch

Emergency switch is above the control box connector.

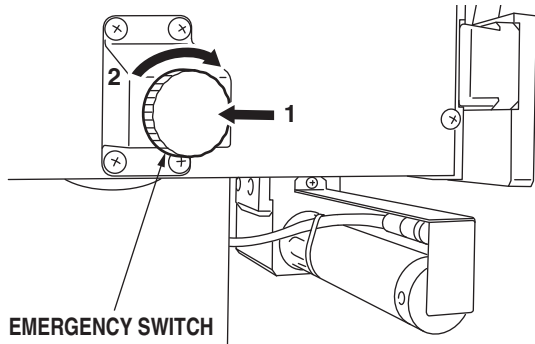

Figure 2-18. Emergency Switch

1. Press the Emergency Stop Switch if operator's or patient's finger gets caught in the joint of back section during operating the back section.
2. Then turn the Emergency Stop Switch to the direction of the arrow and release from activating the Emergency Stop.
3. Lastly press the switch for the opposite operation and release the caught finger.



Please use the emergency switch at the urgent case only.

2-8. Emergency Back-up Controls

a. The emergency back-up control switches are located under the access door on the service access cover in the table base. See figure 2-19.

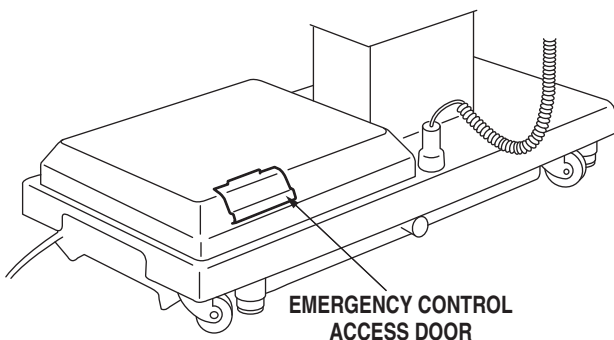

Figure 2-19. Emergency Controls Location

b. In the event of either a power failure or a problem with the hand-held pendant control, the table can be operated using the emergency back-up switches. Simply push the desired emergency switch in the appropriate direction to operate the table functions. See figure 2-20.



The safety interlock system is not operational when the emergency back-up control switches are used.

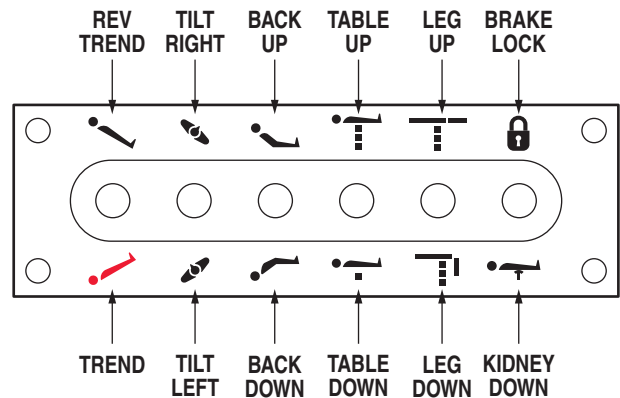

Figure 2-20. Emergency Back-Up Controls



The EMERGENCY BRAKE LOCK switch does not activate the brake system timer. The switch must be held until the brakes are completely locked, approximately 10 seconds.

NOTE

The emergency back-up control switches will function when the table is operating on AC power, battery power, or turned off.

c. Switches are provided for Trendelenburg, lateral tilt, back section, elevation, leg section, kidney down and brake lock. These switches are spring-loaded so they return to the neutral or center position when released.

SECTION II OPERATION

2-9. Emergency Brake Release

In case of a power failure or an electrical problem within the table, the emergency brake release system can be used to move the table. The control knob for this function is located on the side of the table base and is identified by an EMERGENCY BRAKE RELEASE label. Turn the knob clockwise to release the brakes. See figure 2-21.

**WARNING**

DO NOT unlock brakes when a patient is on the table. An uneven patient weight load may cause instability.

**WARNING**

If circumstances demand table brakes to be unlocked, the patient must be centered and evenly distributed on the table top (i.e. Supine or prone position) with the table lowered to its lowest height position. The maximum patient weight should not exceed 230kg. Table top slide must be centered (indicated by a red LED light on the pendant control) prior to unlocking brakes. Patient's head must be on the head section. Head section must be attached in its normal orientation to the table's back section.

**WARNING**

Prior to unlocking brakes, check for obstructions on the floor that might prevent the table from moving smoothly to new location. Re-lock the brakes immediately once the final position is reached and before commencing surgery. To move the table safely one staff member should be positioned at the head end and one at the foot end. If the patient weight exceeds 115kg, four staff members are required to move the table and ensure patient safety. Table brakes should remain locked at all times if patient weight exceeds 230kg.

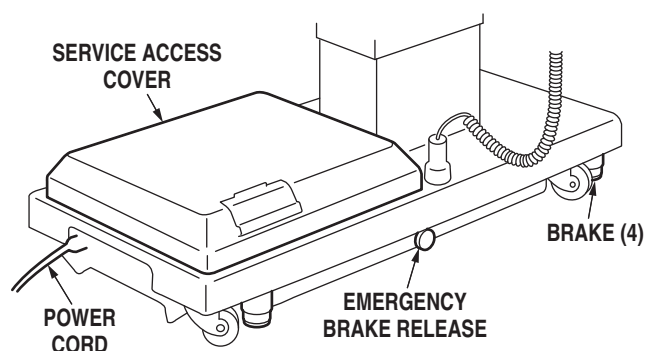

Figure 2-21. Emergency Brake Release

NOTE

- The Emergency Brake Release Valve must be closed and tightened (counter-clockwise) before activating any hydraulic function.
- If the Emergency Brake Release Valve has been operated, the BRAKE UNLOCK button on the pendant control will have to be pressed to reset the timer circuit before brakes will lock again.

SECTION II OPERATION

2-10. Head Section

a. A quick release positioning bar located under and to the front of the head section (figure 2-22) is used to raise or lower the head section. Pull the release bar toward the head end to allow the section to pivot up or down. Positioning from 60° above horizontal to 90° below horizontal in 15° increments is available. Release the bar to lock the head section in position.

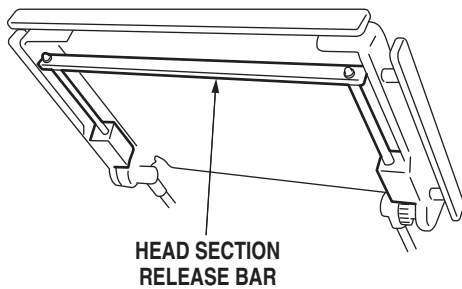

Figure 2-22. Head Section Adjustment

b. If desired, the head section may be removed by loosening the locking knobs and pulling it straight out of the back section.

MOT-3502 Table has the capability of attaching the head section to the leg section for use as a foot extension ONLY. DO NOT reverse the patient on the table without first consulting with MIZUHO.

Two locking knobs are located on the inside of the leg section for securing the head section. See figure 2-23.

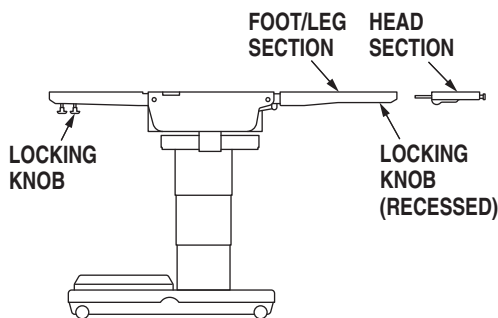

Figure 2-23. Repositioning Head Section (for use as a Foot Extension)

2-11. Leg Section Removal

NOTE

The leg section with the x-ray top + pad attached weighs 14kg. It is recommended that the x-ray top and pad be removed before detaching the leg section.

a. To remove the leg section, position the table top height to elbow height, and simultaneously depress both release levers and pull the leg section out. See figure 2-24. Press the LEG-DOWN button on the pendant control to position the leg section attachment pins down and out of the way.

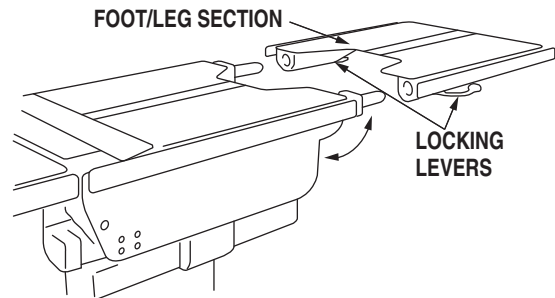

Figure 2-24. Leg Section Release Levers

b. To Install Leg Section, press and hold the LEG-UP button until the leg section attachment pins completely stop before reinstalling the leg section to the table. Pull out on the leg section after installation to make sure the release levers are completely locked.



Ensure that the Leg section is properly engaged and secured to pins before use to prevent injury.

SECTION II OPERATION

**WARNING**

Consult manufacturer's instructions when using high frequency surgical equipment, cardiac defibrillator and cardiac defibrillator monitors. Improper operation procedures might cause a burn on an operators or patient, and also cause the malfunction of the product.

**WARNING**

- When a patient is put on a mattress and his/her position is set up, a patient shall be set up to more than 1 cm apart from a side rail so that a patient dose not touch on side rails (metal).
- The mattress should be attached in order not to come off while being in use.

**WARNING**

When an antistatic pathway is required, the table has to be used on an antistatic floor.

**WARNING**

The antistatic properties of the table are dependent on the use of the original pad set which was furnished with the table or an alternate approved replacement.

2-12. Positioning

The use of certain optional accessories available from MIZUHO further extend the positioning capabilities of the MOT-3502 Table. Refer to the optional accessories manual or contact your MIZUHO representative for further details.

**WARNING**

Certain accessories may limit weight capacities. Check with your MIZUHO representative.

**WARNING**

MIZUHO Products are guaranteed for proper performance with the use of genuine MIZUHO accessories.

Accessories and products not furnished by MIZUHO have not been tested for proper performance and safety. Such applications or use are at the discretion of the user to ensure patient and staff safety.

**CAUTION**

Do not use worn or damaged accessories, they represent an injury hazard.

A patient's position setup is performed under the condition that a mattress is equipped to the upper surface of table top.

1. Attach a mattress to table board.
A mattress which is made by MIZUHO and is exclusive use of this table is used. (Refer to the following Notes)
2. Put a patient on the table.
3. Set up the patient's position in accordance with the purpose of the operation. (Figure 2-25)

SECTION II OPERATION

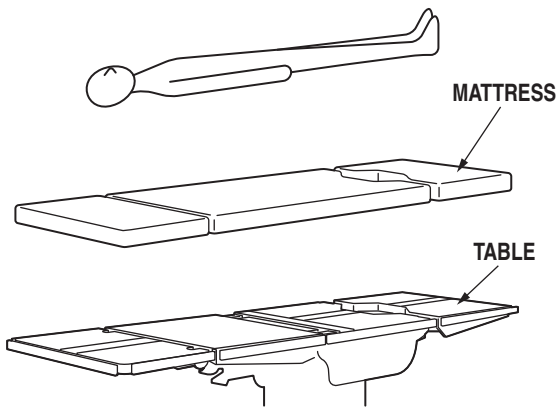

Figure 2-25. Patient Positioning

CAUTION

- MIZUHO surgical tables are designed to be used by trained healthcare professionals only.
- Place a patient on the table after a 70mm minimum thickness mattress is certainly attached onto the table top for safeness of a patient.
- Attach a mattress onto the table properly in order not to slip off or come off the table during operation.
- Install a table board in order not to recognize the screw caps. (Figure 2-26)

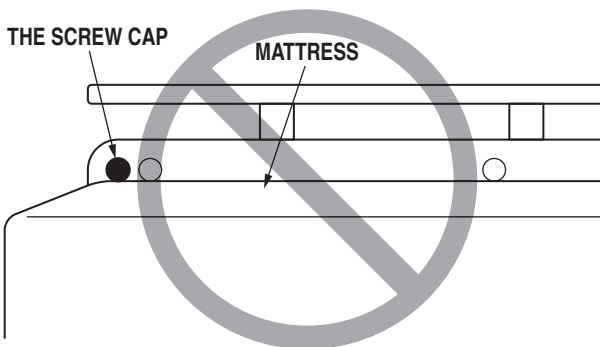

Figure 2-26. Recognize the screw caps

- Put a patient on the table after the mattress is changed to proper position when the mattress is found to be out of proper position.

WARNING

Set up a patient's position in order not to touch the metal parts like table board or side rail of table top directly. Metal part might cause a burn.

NOTE

- A mattress is an applied part.
- Usable mattresses are as following.

50005M2
360L6M2
360L8M2

Mattress's shape is suitable for each table board.

- Tag which indicates that a mattress is an applied part and is made by MIZUHO is attached on a mattress.



Tag

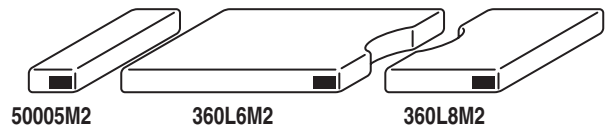

Figure 2-27. Tag of Mattress

SECTION III MAINTENANCE

3-1. Cleaning Recommendations

- Between Cases / Operations

Always follow product cleaning and disinfecting utilization instructions and warnings indicated by cleaning product manufacturer.

**WARNING**

Personal injury to patient or staff may result from a lack of proper maintenance of this equipment.

**CAUTION**

Caution should be taken when cleaning the table to prevent excessive fluid entry into electrical connectors.

a. Cleaning

The following procedures should be followed when cleaning the surgical table between cases.

Place table top in level position prior to starting cleaning procedure.

Before cleaning:

Turn off the table. Apply preventative measures to avoid spraying directly into connectors or electrical receptacles.

**WARNING**

Always follow the national blood-borne pathogens standards for protective clothing, including gloves, masks and eye protection when cleaning the surgical table.

Remove major contaminants from the table with disposable materials following appropriate biohazard waste disposal procedures.

Remove all table pads and place them on a flat surface for cleaning.

**CAUTION**

Thoroughly read and follow the manufacturer's directions for all cleaning fluids. DO NOT use cleaners containing phenolics. Avoid use of oxidizing products with Chloric derivatives such as bleach or Peracetic Acid.

Use a ready to use detergent diluted as required by manufacturer. Check that active ingredients of the product are compatible with the materials of the MIZUHO Table.

Apply cleaning fluid liberally to top and sides of each pad and wipe with a clean lint-free cloth.

Using a clean, damp, lint-free cloth, wipe the pads to remove the cleaning fluid.

Using a clean, dry, lint-free cloth, wipe the pads to remove all moisture.

Repeat the steps to clean the bottom of each pad. Allow to dry.

**CAUTION**

When using spray cleaners DO NOT spray fluids directly into electrical receptacles or micro switches.

Repeat cleaning procedure for all table surfaces including the top, sides, elevation column, base and all accessories.

**CAUTION**

Before replacing pads on the table, make sure the pads and all mating surfaces are completely dry. Moisture trapped between the pads and mating surfaces may cause distortion of table tops.

SECTION III MAINTENANCE

When the cleaning procedure is complete, replace all pads and accessories as applicable.

Remove disconnected pendant control from table side rail and apply cleaning solution to the pendant control and cord.

Avoid immersing the hand control assembly in liquids.

Use a clean cloth dampened with water to remove cleaning solution.

Use another clean damp cloth to remove any remaining residue.

Install pendant control on side rail for storage when cleaning procedure is complete. Allow to dry.

Clean casters and floor lock brakes.

b. Disinfection

The following procedure should be followed when disinfecting an operating table.

1. Remove all table pads from the operating table.
2. Apply a proper quantity of disinfectant on the clean and lint-free cloth, and wipe the top and sides and bottom of the pads with the cloth. A proper quantity of disinfectant means a quantity which the cloth with disinfectant does not dry when wiping.
3. Disinfect the table board of the table top and the surface of side rail in the same procedure.
4. Wipe all disinfected parts with dry, clean and lint-free cloth within 15 minutes after disinfecting.

Usable antiseptic solutions which we have already confirmed are as the following lists.

Use the antiseptic solutions listed as follows.

	Medicine Name
1	0.1% sodium hypochlorite (halogenated chemical)
2	Hypo Alcohol (iodine decolorant)
3	Chlorhexidine (0.5% chlorhexidine gluconate)
4	Benzalkonium chloride (10% invert soap)
5	Povidone iodine
6	80% ethanol
7	Oxydol (hydrogen peroxide)
8	Isopropyl alcohol (IPA)

3-2. Routine Inspections

- Performed Daily by Operator

The following inspections should be done before and after each use of the table.

- a. Inspect all table pads for damage.
- b. Inspect all table top sections for damage.
- c. Inspect the table top assembly, all top sections and the base for stability.
- d. Inspect the power cord and plug for any signs of burns or damage.
- e. Test the operation of the main power switch.
- f. Test all functions of the pendant control for proper table movement.
- g. Inspect the table base surface and the floor for any signs of oil leaking.
- h. Perform steps of cleaning procedure.
- i. Recharge batteries / check battery charge.

SECTION III MAINTENANCE

**CAUTION**

Do not use the table if any of the inspection points fail.

- Performed weekly

- a. Check each function for movement to ensure quiet and smooth operation.
- b. Check auto interlock system function and audible alarms.
- c. Check the overall condition of the hand control.

- Performed monthly

- a. Inspect casters and hydraulic floor lock assembly, clean as necessary.
- b. Inspect the emergency back-up switches for operation.
- c. Inspect hand control cord condition.
- d. Inspect table pad condition.

3-3. Preventive Maintenance

The following preventive maintenance checks and services are recommended to ensure the serviceability and proper operation of your MIZUHO Surgical Table. Maintenance must be performed by a MIZUHO authorized service representative using MIZUHO authorized replacement parts and service techniques.

During normal cleaning, a general visual examination should be made checking for leaks, loose bolts or parts, and cracked, chipped, or missing paint. Any necessary repairs should be made.

Annually or as required based on usage, the following checks and services should be performed:

- a. Check all hydraulic fittings, mini-valves and slave cylinders for proper operation and any signs of leaks.
- b. Check the hydraulic speed controls and adjust if necessary.
- c. Pressure check (with a gauge) the pressure relief valve.
- d. Check all mechanical adjustments and adjust as necessary.
- e. Check hydraulic fluid level.
- f. Lubricate the slider assembly.
- g. Check function of leg section release levers, lubricate as necessary.
- h. Check the recharging of batteries:
 - Whenever table is placed into use
 - Whenever the last bar on power panel is displayed.
 - Whenever the table is unused for an extended period of time.
- i. Check table top level function.
- j. Inspect emergency back-up controls.

3-4. Operator Troubleshooting**Troubleshooting Notes:**

When troubleshooting a table malfunction, first determine the following:

1. Does the problem affect all control functions?
2. Does the problem affect only one control function?
3. If the problem affects one control function is it in both directions?
4. Is the problem intermittent?
5. Is the problem no movement of a table surface or does the table surface lose position?

MALFUNCTION	POSSIBLE CAUSE	CORRECTIVE ACTION
Table will not turn on	Mains switch off	Turn on Mains switch
	Defective hand control	Replace hand control
No movement	Totally discharged batteries	Charge table batteries
	Defective hydraulic pump	Contact MIZUHO Service
	Defective control box	
	Defective hydraulic valve	
Defective hand control		
Table remains on battery mode when main power cord is connected	Incorrect Mains connection	Reconnect - correct Mains connection
	Defective power cord	Replace power cord
	Main breaker blown	Reset Mains circuit breaker
	Main power is off	Turn Mains power switch on
Power falls even though the battery is charged	Battery is degraded	Contact MIZUHO Service
The status of Battery Indicator is 2red	Fuse is degraded	Contact MIZUHO Service

Replacement and reconnect of battery and fuse and reset of breaker have to be performed by trained service staff of MIZUHO. If corrective actions for the following symptoms are necessary, be sure to contact an agency of MIZUHO.

Battery powered tables must always be equipped and operated with (2) 12V lead acid sealed batteries available only through MIZUHO.

- Grounding reliability can only be achieved when the equipment is connected to a properly grounded receptacle. Where the integrity of the external Protective Earth Ground is compromised equipment must be operated on battery mode if applicable.
- Use only MIZUHO Replacement Parts for power cord and pendant control. Refer to Replacement Parts section.

SECTION III MAINTENANCE

3-5. Maintenance Checks & Services

Refer to Replacement Parts Section IV for component locations.



CAUTION

Always inspect product prior to use to ensure safe and correct operation. Any product deemed to be malfunctioning should be removed from service immediately and labeled inoperable. Refer all service to a MIZUHO authorized service representative.

a. Head Section

Ensure both Head Section Locking Knobs are installed, they have full range of motion, and their threads are not stripped. Refer to figure 3-1.

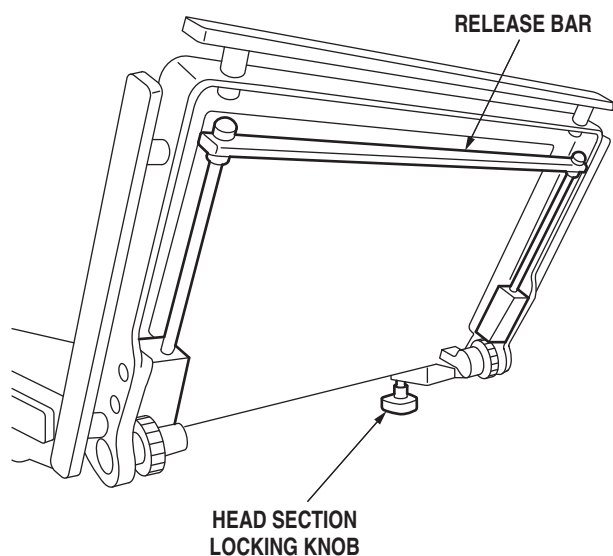

Figure 3-1. Head Section

Ensure the Acorn Nuts on Head Section Release Bar are tightly secured.

Ensure the Head Section Release Bar Plunger properly engages the Head Section Trunnion Gears.

Ensure all Side Rail Fasteners are installed and secured tightly.

Ensure the Head Section Extension Shafts are not deformed and provide smooth full range movement. Place a small amount of White Lithium Grease on the Head Section Release Bar Plunger and the Head Section Trunnion Gears.

Ensure the Head Section is level (parallel to the floor) and even with the Back Section. If it is not, notify a certified MIZUHO technician.

b. Top Section Components

Ensure the Leg Section Release Levers lock and release properly. Refer to figure 3-2.

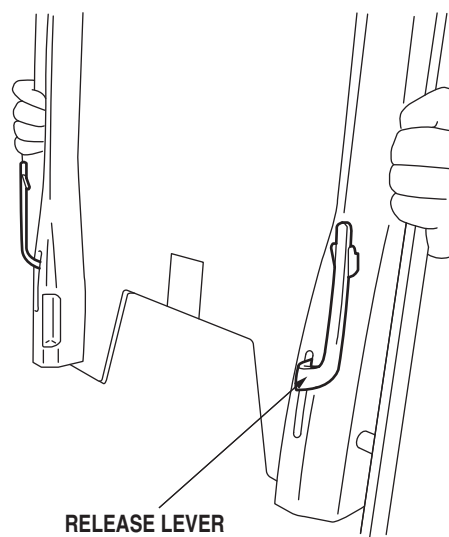

Figure 3-2. Leg Section

SECTION III MAINTENANCE

Ensure the Leg Section Pins are not distorted and the Leg Section slides smoothly on the Leg Section Pins.

Apply a thin coat of White Lithium Grease to both Leg Section Pins.

Lower the Leg Section 90 degrees to ensure that the Leg Section Release Levers Gravity Stops prevent disengagement.

Ensure both Side Rail Gravity Stops are installed and move freely.

Ensure that all Warning Labels are present and readable.

Ensure the Table Top Sections are not cracked or warped. Replace as needed.

Ensure the Table Top Sections securing Screw Heads do not have sharp burrs.

Place an X-Ray Top into the Table Top Sections to ensure that it has a snug fit.

Ensure the Leg Section does not "Search", continuous alternating raising and lowering, when returning the Leg Section to level. This micro-switch adjustment, if needed, can only be performed by a MIZUHO authorized service representative.

Inspect for Hydraulic Oil leaks.

Apply a thin coat of White Lithium Grease to the Kidney Bridge Extension Shafts.

Ensure the Support Bushings rotate when the Back Section is raised.

c. Base Components

Ensure the Power Cord is not frayed, pinched, or otherwise damaged.

Observe that the Power Indicator LEDs and Battery Indicator LEDs are functioning.

Ensure the Ground Equalization Terminal Post is installed and is securely attached.

Observe that the Hand Control Pendant cover is not torn or has sections missing. Replace as needed.

Ensure the Hand Control Pendant cord is not frayed, pinched, or otherwise damaged.

Test each Hand Control Pendant Articulation Button for full range of travel.

After the AC Power and Battery are turned OFF, Briefly toggle each Emergency Back Up Switch to ensure operation.

SECTION III MAINTENANCE

Test the Hand Control Pendant's Brake Unlock Button and Lock Button functions.

Open the Emergency Brake Release Valve to ensure proper operation.

Inspect for Hydraulic Oil on the Base, under the Access Cover, and on all four Brakes.

Inspect the Hydraulic Oil level.

The Hydraulic Oil level should be approximately ½" below the filler hole gasket surface.

NOTE

The elevation cylinder should be completely down, the brakes released and all the other control functions in their neutral position when checking hydraulic oil level.

Ensure the Shroud Assemblies are not damaged and slide smoothly.

Ensure all screws are installed and secured tightly.

Ensure all four Casters rotate 360 degrees on both axis. Ensure there are no flat spots on the Caster.

Ensure there are four Brake Pads and the pads are not chipped or otherwise damaged.

3-6. Maintenance Matrix

The specific items listed in the MAINTENANCE MATRIX shall be inspected and repaired or replaced as necessary. The suggested time intervals are intended as a guideline only and actual maintenance will vary by use and conditions. For optimal usage, safety and longevity of the product, have it serviced only by a MIZUHO authorized service representative using MIZUHO authorized replacement parts and service techniques.

SECTION III MAINTENANCE

SURGICAL TABLE MAINTENANCE MATRIX

Component	1 Year	2 Years	5 Years	7 Years
Lateral Tilt Housing Bolts	X			
Side Rails & Gravity Stops	X			
Velcro	X			
Hydraulic Oil Level	X			
A.C. Power Cord	X			
Self-Leveling Brake Pad	X			
Casters	X			
Lubricate Elevation Column	X			
Tighten X-Ray Top Standoffs & Apply Blue Loctite®	X			
Back Section Cylinder	X			
Trendelenburg Cylinder and Retainer Nut	X			
Lateral Tilt Cylinder	X			
Elevation Cylinder	X			
Kidney Lift Cylinder	X			
Foot-Leg Section Cylinder	X			
Slide Cylinder	X			
Plumbing & Terminal Block Assembly	X			
Battery, 12 Volt		X		
Brake Pads			X	
Pendant Control Assembly			X	
Main ON/OFF Switch				X
Power Cord Receptacle				X
Pendant Control Connectors				X
Grounding Lead				X
Back Section Micro Switches				X
Trendelenburg Micro Switches				X
Leg Section Micro Switches				X
Lateral Tilt Micro Switches				X
Brake Cylinders				X
Emergency Brake Release Valve				X
Pump/Motor Assembly				X
Pressure Relief Valve Assembly				X
Hydraulic Oil System Flush				X
Mini-Valves				X
Riser Cord Assembly				X
Slider Column				X
Elevation Shroud Gasket				X
Access Cover Gasket				X
Labels & Operation Decals				X

SECTION III MAINTENANCE

3-7. Service

Required table maintenance should be performed by a MIZUHO authorized service representative using MIZUHO authorized replacement parts and service techniques.

Preventive Maintenance contracts are available through your local MIZUHO representative.

To obtain MIZUHO authorized service or preventive maintenance contracts, contact your nearest MIZUHO representative or write or call:



WARNING



- DO NOT disassemble the table. Unauthorized disassembling may cause electric shock or malfunction.
- Please contact your local distributor or manufacturer for maintenance or repair. The operating table should only be serviced or maintained by a factory trained personnel.

NOTE

Technical description of this product is due to the Maintenance Manual. The contents of Maintenance Manual are as follows.

SECTION I	HYDRAULIC SYSTEM
SECTION II	MECHANICAL TABLE ADJUSTMENTS
SECTION III	HYDRAULIC TROUBLESHOOTING
SECTION IV	ELECTRICAL SYSTEM
SECTION V	ELECTRICAL TROUBLESHOOTING

Maintenance Manual can be obtained only by the person who has had the service training of MIZUHO.

The durability of this operating table is 10 years.

Manufacturer

MIZUHO Corporation
3-30-13 Hongo, Bunkyo-ku
Tokyo 113-0033, Japan
<https://www.mizuho.co.jp>

European authorized representative:

EMERGO EUROPE
Westervoortsedijk 60
6827 AT Arnhem,
The Netherlands

3-8. Disposal

In accordance with the European Union Waste Electrical and Electronic Equipment (WEEE) Directive, all electrical components and batteries must be disposed of in accordance with local regulations. Please contact your local distributor for proper disposal.

Pay special attention to the following disposals:

- Hydraulic Fluid
- Lead Acid Batteries

SECTION IV ELECTROMAGNETIC EMISSIONS

Install and operate according to the EMC information provided in this manual.



WARNING

- Do not use any accessories other than those specified by our company.
This can result in increased emissions and reduced immunity.
- Do not use it adjacent to or stacked with other equipment.
Normal operation may not be possible due to electromagnetic interference.
- Before using other medical electronic devices (especially life support devices) to be used together, make sure that they will not malfunction due to electromagnetic interference.
Normal operation may not be possible due to electromagnetic interference.

Guidelines and manufacturer declaration – electromagnetic emissions

The MOT-3502 is intended for use in the electromagnetic environment specified below.

The customer or user of the MOT-3502 must ensure that it is operated in suchlike environments.

Electromagnetic interference measurement	Compliance	Electromagnetic environment – guideline
Harmonic emissions IEC 61000-3-2	Class A	The MOT-3502 is suitable for use in all establishments, other than domestic establishments and those directly connected to the public low-voltage power supply network that supplies buildings used for domestic purposes.
Voltage fluctuations / flicker emissions IEC 61000-3-3	Complies	
RF emissions CISPR 11	Class A	
RF emissions CISPR 11	Group 1	The MOT-3502 uses RF energy only for its internal function. Therefore, its RF emissions are very low and are not likely to cause any interference in nearby electronic equipment.

SECTION IV ELECTROMAGNETIC EMISSIONS

Guidelines and manufacturer declaration – electromagnetic interference immunity			
The MOT-3502 is intended for use in the electromagnetic environment specified below. The customer or user of the MOT-3502 must ensure that it is operated in suchlike environments.			
Interference immunity tests	IEC 60601 test level	Compliance level	Electromagnetic environment – guidelines
Electrostatic discharge (ESD) IEC 61000-4-2	± 8 kV contact discharge ± 2; 4; 8; 15 kV air discharge	± 8 kV contact discharge ± 2; 4; 8; 15 kV air discharge	Floors should be wood, concrete or ceramic tile. If floors are covered with synthetic material, the relative humidity should be at least 30%.
Electrical fast transient / burst IEC 61000-4-4	± 2 kV for power supply lines ± 1 kV for input and output lines	± 2 kV for power supply lines ± 1 kV for input and output lines	Power supply voltage quality should be that of a typical commercial or hospital environment.
Surge IEC 61000-4-5	± 0,5; 1 kV differential mode voltage ± 0,5; 1; 2 kV common mode voltage	± 0,5; 1 kV differential mode voltage ± 0,5; 1; 2 kV common mode voltage	Power supply voltage quality should be that of a typical commercial or hospital environment.
Voltage drops, short interruptions and fluctuations in power supply voltage IEC 61000-4-11	0 % U_T for 0.5 cycles 0 % U_T for 1 cycles 70 % U_T for 25 / 30 cycles 0 % U_T for 250 / 300 cycles	0 % U_T for 0.5 cycles 0 % U_T for 1 cycles 70 % U_T for 25 / 30 cycles 0 % U_T for 250 / 300 cycles	Power supply voltage quality should be that of a typical commercial or hospital environment. If the user of the MOT-3502 need to continue operation during a mains power interruption, it is recommended that the MOT-3502 be powered by an uninterruptible power supply or battery.
Power frequency (50/60 Hz) magnetic field IEC 61000-4-8	30 A/m	30 A/m	Power frequency magnetic fields should be at levels characteristic of a typical location in a typical commercial or hospital environment.
Info: U_T is the AC voltage before application of the test level			

SECTION IV ELECTROMAGNETIC EMISSIONS

Guidelines and manufacturer declaration – electromagnetic interference immunity (continuation)																																																																			
Conducted disturbances induced by radiated RF IEC 61000-4-6	150 kHz to 80 MHz 3 V	150 kHz to 80 MHz 3 V	Portable and mobile RF communications equipment (radio devices, incl. antennas or cables) should be used no closer to any part of the MOT-3502 than the recommended safety distance of 300mm (or 12inches).																																																																
	ISM frequencies 6 V	ISM frequencies 6 V																																																																	
Interference due to radiated RF IEC 61000-4-3	80 MHz to 2.7 GHz 3 V/m	80 MHz to 2.7 GHz 3 V/m	The field strengths from fixed RF transmitters, as determined by field surveys of electromagnetic fields, should be less than a compliance level of 3 V/m in each frequency range. Interference may occur in the vicinity of equipment marked with the following symbol: 																																																																
	Wireless communication frequency band	Wireless communication frequency band																																																																	
	<table border="1"><thead><tr><th>V/m</th><th>MHz</th></tr></thead><tbody><tr><td>27</td><td>385</td></tr><tr><td>28</td><td>450</td></tr><tr><td>9</td><td>710</td></tr><tr><td>9</td><td>745</td></tr><tr><td>9</td><td>780</td></tr><tr><td>28</td><td>810</td></tr><tr><td>28</td><td>870</td></tr><tr><td>28</td><td>930</td></tr><tr><td>28</td><td>1720</td></tr><tr><td>28</td><td>1845</td></tr><tr><td>28</td><td>1970</td></tr><tr><td>28</td><td>2450</td></tr><tr><td>9</td><td>5240</td></tr><tr><td>9</td><td>5500</td></tr><tr><td>9</td><td>5785</td></tr></tbody></table>	V/m		MHz	27	385	28	450	9	710	9	745	9	780	28	810	28	870	28	930	28	1720	28	1845	28	1970	28	2450	9	5240	9	5500	9	5785	<table border="1"><thead><tr><th>V/m</th><th>MHz</th></tr></thead><tbody><tr><td>27</td><td>385</td></tr><tr><td>28</td><td>450</td></tr><tr><td>9</td><td>710</td></tr><tr><td>9</td><td>745</td></tr><tr><td>9</td><td>780</td></tr><tr><td>28</td><td>810</td></tr><tr><td>28</td><td>870</td></tr><tr><td>28</td><td>930</td></tr><tr><td>28</td><td>1720</td></tr><tr><td>28</td><td>1845</td></tr><tr><td>28</td><td>1970</td></tr><tr><td>28</td><td>2450</td></tr><tr><td>9</td><td>5240</td></tr><tr><td>9</td><td>5500</td></tr><tr><td>9</td><td>5785</td></tr></tbody></table>	V/m	MHz	27	385	28	450	9	710	9	745	9	780	28	810	28	870	28	930	28	1720	28	1845	28	1970	28	2450	9	5240	9	5500	9	5785
	V/m	MHz																																																																	
	27	385																																																																	
	28	450																																																																	
	9	710																																																																	
	9	745																																																																	
	9	780																																																																	
	28	810																																																																	
	28	870																																																																	
	28	930																																																																	
	28	1720																																																																	
	28	1845																																																																	
	28	1970																																																																	
28	2450																																																																		
9	5240																																																																		
9	5500																																																																		
9	5785																																																																		
V/m	MHz																																																																		
27	385																																																																		
28	450																																																																		
9	710																																																																		
9	745																																																																		
9	780																																																																		
28	810																																																																		
28	870																																																																		
28	930																																																																		
28	1720																																																																		
28	1845																																																																		
28	1970																																																																		
28	2450																																																																		
9	5240																																																																		
9	5500																																																																		
9	5785																																																																		
Info : These guidelines may not apply in all situations. Electromagnetic propagation is affected by absorption and reflection from buildings, objects and people.																																																																			
The field strengths from fixed transmitters, such as wireless (cellular / cordless) telephones and mobile terrestrial radio base stations, amateur radio, AM / FM radio broadcasts and TV broadcasts cannot be accurately and theoretically predicted. In order to confirm the electromagnetic environment caused by the fixed RF transmitter, it is desirable to consider an electromagnetic field survey. If the measured field strength exceeds the compliance level as specified above at the location where the MOT-3502 is used, the MOT-3502 should be observed to verify correct functionality. If abnormal performance is observed, additional measures may be necessary, such as re-orienting or relocating the MOT-3502.																																																																			



Sales Agent



EMERGO EUROPE
Westervoortsedijk 60
6827 AT Arnhem, The Netherlands



MIZUHO Corporation

3-30-13 Hongo, Bunkyo-ku
Tokyo 113-0033, Japan
<https://www.mizuho.co.jp>