

Instruction for Use

Trade Name: Knee Crutches with Foot Support

Warning

1. When using operating table accessories, always pay close attention to the patient. Patients left in the same posture for an extended period of time are at risk for developing the compartment syndrome, neuropathy, neuro paralysis bedsores and /or redness.
2. Set this product symmetrically for both legs. If it is displaced at one side, a serious neuropathy or interruption in the blood circulation could occur on the hip joint of patient.
3. When adjusting the position of the Thigh rest, always operate the Thigh rest fixing handle while holding the patient's leg. Otherwise the Thigh rest may move suddenly, causing a serious neuropathy or interruption in the blood circulation.
4. Adjust the height and the angle of open legs slowly. Abrupt movement could cause a serious neuropathy or interruption in the blood circulation.
5. Avoid compression of the lateral aspect of the peroneal nerve. Failure to do so could cause paralysis.

Contraindication/Prohibition

1. This product is only validated for use with Mizuho operating tables.
2. Do not place the patient's leg directly on the device. Doing so could result in a burn or nerve paralysis.

Symbol mark for labeling

MD : Medical Device

Specifications

1. Shape

Unit: mm

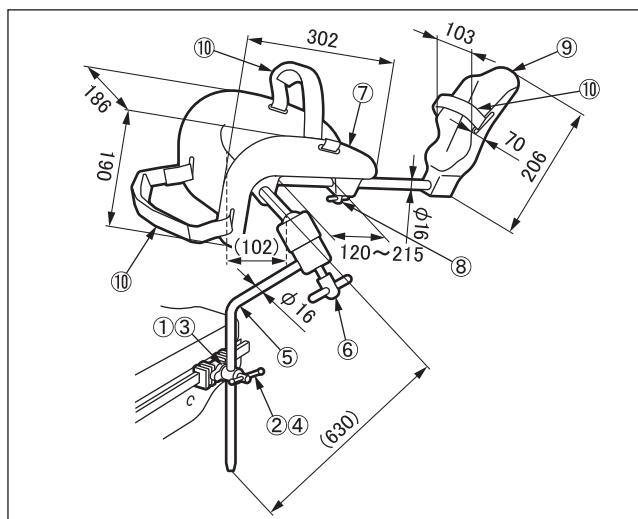

| Code No. | Product Description |
|--------------|---------------------------------|
| 08-072-00-UE | Knee crutches with foot support |
| 08-117-09 | Clamp for Round Bar (R1) *1 |
| 08-117-11 | Clamp for Round Bar (R2) *2 |

*1 and *2: The size of mountable side rail is different.

2. Weight

Main unit: 4.5 kg/pc.

Clamp for Round Bar: 0.9 kg/pc.

3. Material

- ①,③ Rail clamp: Stainless steel casting
- ②,④ Fixing handle: Stainless steel bar
- ⑤ Support pole: Stainless steel bar
- ⑥ Thigh rest fixing handle: Stainless steel bar
- ⑦ Thigh rest: Aluminum alloy casting
- ⑧ Footrest fixing handle: Stainless steel bar
- ⑨ Footrest: Aluminum alloy casting
- ⑩ Fixing belt: Nylon

Note: The number corresponds to those used in 1. Shape.

4. Operating range

Footrest travel: 95 mm max. (Manual)

Intended purpose

This is an accessory to an operating table.

This is a tool with a footrest to be used for supporting the patient's legs mainly in the lithotomy position for a urological, gynecological or similar operation or examination.

Intended user

This product is to be used by health care professionals, including but not limited to surgeons, nurses and biomedical technicians.

Instructions for use

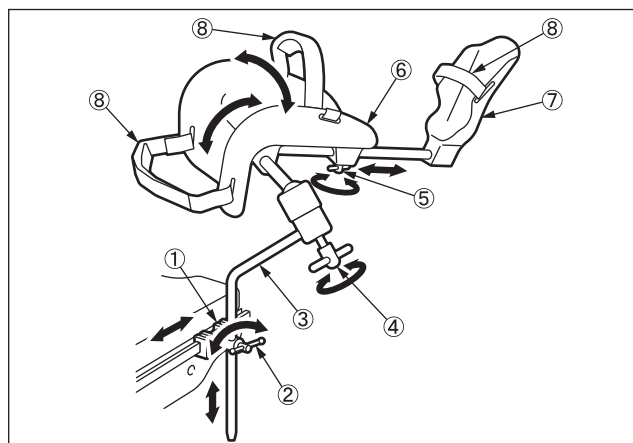

1. Attach the Rail clamps ① to the side rails of the operating table.
2. Insert the Support poles ③ in the Rail clamps ①.
3. Adjust the position of the Support poles ③ according to the posture of the patient, and tighten the Fixing handles ②.
4. Adjust the position of the Thigh rests ⑤ and the Footrests ⑦, and tighten the Thigh rest fixing handles ④ and the Footrest fixing handles ⑥.
5. Fix the patient's thighs and feet with the Fixing belts ⑩.

Warning/Caution

1. Warning

Ensure all fixing handles are tight. Loose condition can cause the product to come off or move, which may result in a patient injury.

2. Important fundamental cautions

2-1. When working with an operating table, take care not to allow this product to make contact or interfere with the table top or with other tools and appliances used in combination with this product. Otherwise the product could break.

2-2. Set this product symmetrically for both legs.

2-3. Protect the legs by covering the Thigh rests with "Urethane Pad for Knee Crutches" or appropriate padding.

2-4. For hygiene, be sure to use sterilized drapes on the areas on this product where the patient comes into contact with it.

3. Defect/Adverse event
[Following nonconformity or adverse event could be encountered during the use of this product (not limited to these). If any of such anomaly is discovered, take necessary action.]

3-1. Defect

- Malfunction
- Failure
- Damage

3-2. Serious adverse event

- Injury
- Neuro paralysis
- Compartment syndrome
- Muscle crush syndrome
- Crush syndrome
- Circulatory disturbance

4. Important cautions

- 4-1. Users should be trained to get used to the usage of the product before using it to the patient.
- 4-2. The patient may inform the medical staff of the postural limits before being anesthetized. Confirm the posture with the patient before fixing.
- 4-3. When using this product, palpate the dorsalis pedis artery, check the skin color and temperature of the legs to see if there is no impaired blood flow.

Storage/Life

1. Do not store the device in high temperatures or in areas with high humidity where the temperature has drastic variations.
2. Service life of this product: 7 years
(Subject to the specified maintenance and inspection and is stored properly.)

Maintenance/Inspection

<By the user>

1. Inspection before and after use
Check that this product is not damaged or broken before and after each use.
2. Cleaning and disinfection
Wipe off blood, chemicals, contaminants, and other stains with water, and clean the device with gauze or other material moistened with alcohol to disinfect.
3. In case of a malfunction
When this product is broken, clearly label the device as "Broken", "Do not use", "Need repair", etc., and contact your local dealer or Mizuho.

<By agents>

Maintenance and inspection can only be carried out by certified agents of Mizuho.

Packing

1 pair per package

Warranty

MIZUHO Corporation will repair defective parts of this product without charge for one year from the date of delivery/installment except for cases of damage caused by a third party's repair, act of nature, improper use or intentional damage. All other warranty terms and conditions are subject to regulations of MIZUHO Corporation.

Disposal

This device must be disposed of in accordance with local regulations. Please contact your local distributor for proper disposal.

Notice

Any serious incident that has occurred in relation to the device should be reported to the manufacturer and the competent authority in which the user and/or patient is established.

Manufacturer



MIZUHO Corporation
3-30-13 Hongo, Bunkyo-ku, Tokyo 113-0033, Japan
<http://www.mizuho.co.jp>

European authorized representative



Emergo Europe B.V.
Prinsessegracht 20, 2514 AP, The Hague
The Netherlands